

JONIX duct

USE AND MAINTENANCE MANUAL

JONIX duct
70MIC2C



JONIX duct
70MIC2F

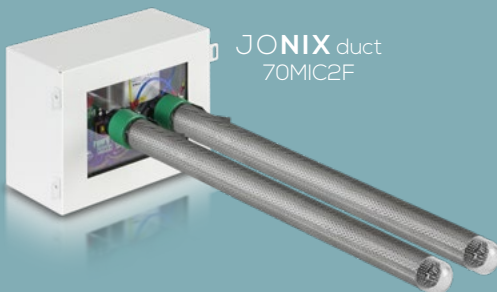

JONIX duct
70MIC4C



JONIX duct
70MIC4F

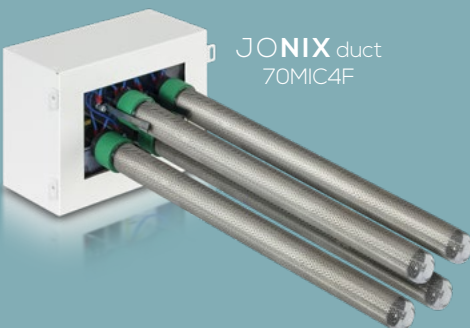

DUCTABLE IONISING
MODULE



These instructions are translated from Italian (the original language).

JONIX S.p.A. reserves every right concerning this manual, including the right to make any necessary change or improvement to its products and to the manual at any time and without notice. It is forbidden to reproduce in full or in part this manual without JONIX S.p.A.'s consent.

TABLE OF CONTENTS

1 - GENERAL INFORMATION	5
1.1 - SERIAL NUMBER PLATE	5
1.2 - LIABILITY	5
1.3 - SYMBOLS	6
2 - WARNINGS AND GENERAL PROHIBITIONS	6
3 - THE OPERATING SYSTEM	8
4 - TECHNICAL DATA JONIX duct	9
4.1 - COMPONENT DESCRIPTION JONIX duct	9
4.1.1 - Technical features JONIX duct	9
4.2 - SPARE PARTS AVAILABLE ON ORDER JONIX duct	9
5 - RECEPTION, TRANSPORT AND STORAGE	10
5.1 - PACKAGING	10
5.2 - HANDLING AND TRANSPORT	10
5.3 - INSPECTION UPON RECEPTION	10
5.4 - STORAGE	10
5.5 - HANDLING DEVICE IN OPERATING CONDITIONS	10
6 - INSTALLATION AND COMMISSIONING	11
6.1 - SAFETY STANDARDS	11
6.2 - GETTING STARTED	12
6.3 - CHOOSING THE INSTALLATION SITE	12
6.4 - INSTALLING THE DEVICE	13
6.5 - ELECTRICAL CONNECTIONS	14
6.6 - ELECTRIC POWER SUPPLY	14
6.6.1 - Control electronics	15
6.7 - USING THE DEVICE	18
7 - MAINTENANCE	19
7.1 - WARNINGS	19
7.2 - ROUTINE MAINTENANCE	19
7.2.1 - Cleaning the Ionising Tubes	20
7.2.2 - External cleaning of the equipment	22
7.3 - SPECIAL MAINTENANCE	23
7.3.1 - Replacing the Ionising Tubes	23
8 - OPERATIONAL CHECK AND TROUBLESHOOTING	25
9 - DISPOSAL	26
ATTACHMENTS	27
OVERALL DIMENSIONS JONIX duct 70MIC2C	27
OVERALL DIMENSIONS JONIX duct 70MIC4C	28
OVERALL DIMENSIONS JONIX duct 70MIC2F	29
SPECIFICATIONS FOR INSTALLATION JONIX duct 70MIC2F	30
OVERALL DIMENSIONS JONIX duct 70MIC4F	31
SPECIFICATIONS FOR INSTALLATION JONIX duct 70MIC4F	32
TEMPLATE OF CUT ON METAL CHANNEL FOR INSTALLATION JONIX duct 2C AND 2F	33
TEMPLATE OF CUT ON METAL CHANNEL FOR INSTALLATION JONIX duct 4C AND 4F	34
TEMPLATE OF HOLE FIXING SUPPORT BRACKET JONIX duct 70MIC2F	35
TEMPLATE OF HOLE FIXING SUPPORT BRACKET JONIX duct 70MIC4F	36

Thank you purchasing the JONIX duct device.

This manual contains the information and all that is required for the transportation, installation, use and maintenance of the Ductable Ionising Module JONIX duct.

Improper installation of the device and/or failure to comply with the instructions in this manual, may invalidate the warranty that the Manufacturer issues for its products.

The Manufacturer is not liable for any direct and/or indirect damage caused by incorrect installation or damage caused by the units installed by inexperienced and/or unauthorised staff. At the time of purchase, check that the device is intact and complete.

The Manufacturer declines any liability in case of personal injury or property damage resulting from any improper use of the device or from the failure to observe the use and safety instructions specified in this manual. In any such case, any warranty claim will be void.

Any complaints must be submitted in writing within **8 days** of receiving the goods.

For more information, download of the manual or video tutorial, we invite you to visit www.jonixair.com.

1 - GENERAL INFORMATION

1.1 SERIAL NUMBER PLATE

The equipment described in this manual is provided with a plate containing the equipment and Manufacturer data:

 Fabbricante	JONIX S.p.A. S.B. Viale Spagna, 31/33 35020 Tribano (PD)
Nome del prodotto	JONIX duct
Descrizione del prodotto	Dispositivo per la sanificazione attiva e purificazione dell'aria
Codice prodotto	REF 70MICxx
Numero di serie	SN xxxxxxxxxxxx
Allimentazione	230V / ~1 / 50Hz
Max Corrente assorbita	xx A
    	

The Ductable Ionising Module JONIX duct is in compliance with Directives 2011/65/UE, 2014/30/UE, 2014/35/UE and subsequent amendments.

IMPORTANT WARNING

The JONIX duct device is designed and made to sanitise the air in residential environments that are incompatible with toxic and flammable gases. It is therefore strictly forbidden to use the device in environments where the air is mixed with and/or altered by other gaseous compounds and/or solid particles. Using the device for purposes other than those intended and that do not comply with those described in this manual, will immediately relieve the manufacturer and its distributors from any direct and/or indirect liability.

1.2 LIABILITY

Failure to comply with the instructions contained in this Use and Maintenance Manual releases JONIX S.p.A. from any liability. For any data not included or not deducible from the following pages it is recommended to consult JONIX S.p.A. directly.

JONIX S.p.A. Benefit Corporation
 Viale Spagna 31/33
 35020 Tribano - PD - Italy
<http://www.jonixair.com>

In particular, if the maintenance of the device is carried out in a manner that does not comply with the instructions provided, or in any case in such a way as to compromise its integrity or modify its characteristics, JONIX S.p.A. will be relieved of any responsibility regarding the safety of persons, property, animals and the faulty operation of the devices.

1.3 SYMBOLS

Please pay utmost attention to the following symbols and their meaning. They emphasise specific information, such as:



WARNING: It refers to integrations or suggestions concerning the proper use of the device.



HAZARD: It refers to dangerous situations that may result from the use of the device, in order to ensure personal safety.



FORBIDDEN: This symbol refers to operations that must be avoided under any circumstances, and hence forbidden.



HIGH VOLTAGE HAZARD!

Do not open or remove any doors or protections before disconnecting the voltage supply.



WARNING!

It is mandatory to use protective gloves.



WASTE FROM ELECTRICAL AND ELECTRONIC EQUIPMENT.

The crossed-out wheeled bin symbol on the equipment label indicates that the equipment is compliant with the Waste Electrical and Electronic Equipment (WEEE) Directive. Disposing of the equipment freely in the environment or illegally disposing of the equipment are punishable by law.

2 - WARNINGS AND GENERAL PROHIBITIONS



This instruction manual is an integral part of the device and therefore must be kept carefully and must ALWAYS accompany the device, even in the event that it is sold to another owner or user or transferred to another facility. In the event that it is damaged or lost contact JONIX S.p.A. for another copy or download the document from www.jonixair.com.



Repairs and maintenance work must be carried out by JONIX S.p.A. authorised staff or by qualified staff according to the provisions set out by this manual. Do not alter or tamper with the device as it can lead to hazards and the manufacturer of the device shall not be liable for any damage caused.



After removing the packaging check that the contents are intact and complete. In the event of a noncompliance please contact the Company that sold you the device.



When installing, commissioning and operating this product, it is mandatory to observe the requirements and instructions specified in this manual.



JONIX S.p.A. disclaims any liability for damage caused to people, animals or property due to installation, adjustment and maintenance errors or by improper use.

Please note that the use of products that require electricity, involves the observance of some crucial safety rules such as:



This device is not intended for use by people (including children) with reduced physical, mental or sensory capabilities or without experience and knowledge, unless they are supervised or are given instructions to use the appliance by a person responsible for their safety. Take suitable precautions to prevent children from playing with the device.



Do not touch the device if you are barefoot and with parts of the body that are wet or damp.



Do not carry out any maintenance or cleaning operations without having first disconnected the device from the mains, by turning the main system switch to "OFF".



Do not alter the safety or adjustment devices without prior authorisation and instructions from the manufacturer of the device.



Do not pull, detach or twist the electrical wires coming out of the device, even when it is disconnected from the mains.



Do not stand, sit and/or rest any type of object on the device.



Do not spray or throw water or other liquids directly onto the device.



Do not open the panels for accessing the internal parts of the device without having first turned the system switch to "OFF".



Not dispose of or leave the packaging materials within reach of children because it can be potentially dangerous.

3 - THE OPERATING SYSTEM

This sanitization device, by exploiting the physical process of ionisation, promotes the controlled formation of particular ionic species (electrically charged species) in the air, through an electrostatic field that simulates the natural process that normally occurs through solar radiation, mechanically or by means of other physical phenomena.

The particular ionic species produced have proved to be particularly effective as sanitizing agents in the air and on surfaces, moreover are historically and scientifically proven to be beneficial in people, especially those with a negative electrical charge (arising from individual or small groups of molecules that receive an electron).

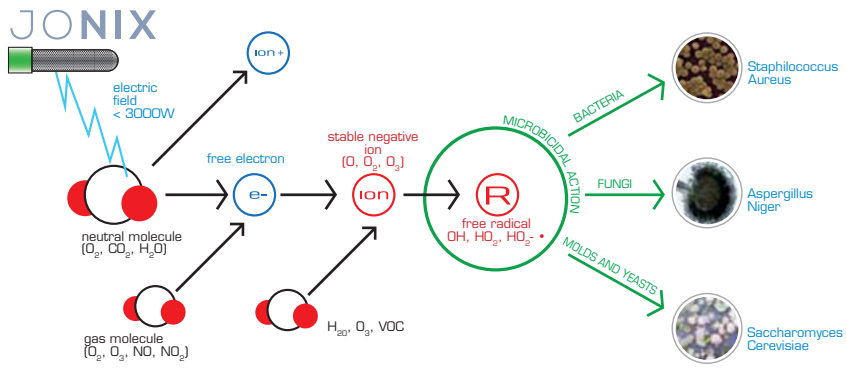

The most significant features of JONIX duct are:

- **High efficiency:** reduction of bioburden and of volatile organic compounds up to 99% compared to the initial concentration;
- **Low power consumption:** from 10 to 40 VA;
- **Strong deodorizing action:** it eliminates odours from the air flowing through;
- **Natural process:** it does not use nor produces residual chemical substances.

New generation ionising units are used in the JONIX duct module, characterised by high efficiency and selectivity, which do not produce any significant increases in undesirable by-products such as ozone or nitrous compounds, in irritating or even toxic amounts.

The function of JONIX duct sanitising systems, designed for installation inside different types of aeration systems, is to reduce the bacterial load and to sanitise air introduced into the environments, improving Indoor Air Quality.

They can be used to sanitise machines and aeration ducts or to reduce odours in environments such as kitchens, fish and meat processing facilities, etc.

JONIX duct modules are composed of control electronics, inside an insulated enclosure, and of actuators: the ionising units exposed to the air flow.

The electronics on the device are capable of sending alarms to the central control system, in real time, in case of failures to the ionising system.

As a result, it is easy to implement a software interface capable of displaying messages requesting maintenance when this signal is received.
The the JONIX duct modules can therefore be perfectly integrated in aeration systems commanded by a central control unit.

4 - TECHNICAL DATA JONIX duct

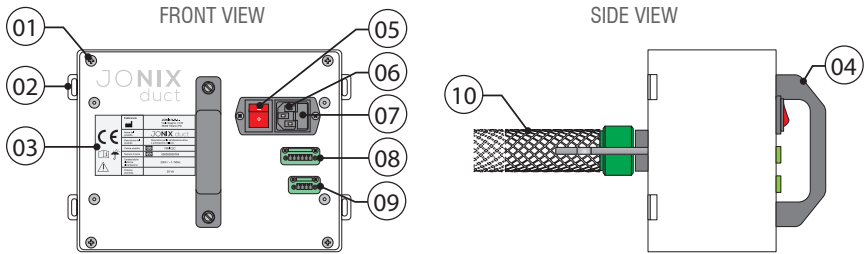

4.1 COMPONENT DESCRIPTION JONIX duct

01	Opening/closing box screws	06	Power supply socket
02	Attachment form stirrup	07	Protection fuse holder
03	Technical statistics label	08	Input and serial signal connector
04	Handle	09	Output and alarm reporting connector
05	Bright ON/OFF switch	10	Ionising tubes with grounding

4.1.1 Technical features JONIX duct

Mod.*	Article	Dimensions (LxPxH) [mm]	Power Supply	Plasma generators	Max sprayed airflow (m³/h)**	Max power absorption [W]	Weight [Kg]
JONIX duct	70MIC2C	290 x 350 x 200	230 V/~1/50Hz	2 x type 175	500	10	4
	70MIC4C	290 x 350 x 200	230 V/~1/50Hz	4 x type 175	1000	20	5
	70MIC2F	290 x 700 x 200	230 V/~1/50Hz	2 x type 520	2000	20	5
	70MIC4F	290 x 700 x 200	230 V/~1/50Hz	4 x type 520	4000	40	6

*): Various models can be assembled in group of the same type or comined according to the airflow to deal with.

**): The maximum sanitized air flow is indicative, the sizing must be calculated by the company based on the characteristics of the environments to be treated.

4.2 SPARE PARTS AVAILABLE ON ORDER JONIX duct

Code	Description	Notes
70CONDTIPO175	CONDENSATORE TIPO 175	2 Ionising generators (for 2C version); 4 Ionising generators (for 4C version);
70CONDTIPO520	CONDENSATORE TIPO 520	2 Ionising generators (for 2F version); 4 Ionising generators (for 4F version);
JX4000009	SINGLE-PHASE PROCESSOR 20VA 230V/2850V	1 processor
JX4000010	SINGLE-PHASE PROCESSOR 40VA 230V/2850V	1 processor
JX11000042	NEW SENSING CARD	1 electronic card
JX40000002	GLASS FUSE 5x20 1A quick	1 quick blow glass fuse

5 - RECEPTION, TRANSPORT AND STORAGE

5.1 PACKAGING

JONIX duct and its accessories are delivered in specific protective packaging and must remain intact until they are assembled. The materials that were not installed for technical requirements are supplied with suitable enclosure secured to the inside or outside of the device itself. The package includes:

- N° 1 ductable Ionising Module JONIX duct.
- N° 1 power supply connector, n° 2 serial connectors.
- N° 1 bracket support of generators (only for 70MIC2F and 70MIC4F versions).
- Operating and maintenance manual.
- Declaration of Conformity.
- Warranty conditions.

5.2 HANDLING AND TRANSPORT



To handle the device use appropriate means, depending on the weight, as required by Directive 89/391/EEC and subsequent amendments.



Please take great care while unloading and positioning the devices, to prevent damaging the casing or components. Avoid uncontrolled rotations.

The weight of every single device is given in this manual.

5.3 INSPECTION UPON RECEPTION

When you receive the device please check all its parts, in order to make sure that it has not been damaged during transport.

Any damage must be reported to the carrier, by filling in the relevant section on the delivery note and specifying the type of damage.



Any type of complaint must be sent in writing within eight days from receiving the goods.

5.4 STORAGE

In the event of extended storage keep the devices away from dust and sources of vibration and heat.



The Manufacturer disclaims any liability for damage due to incorrect unloading failure to protect the device from the elements.

5.5 HANDLING DEVICE IN OPERATING CONDITIONS

JONIX duct device is easy movable in various environments, because it is provided with handle and reduced clearances (see Chapter 4 "Technical Data").



We recommend you the highest attention in handle the plasma generators uin the device.

6 - INSTALLATION AND COMMISSIONING



ATTENTION! Before carrying out any operation on the devices read **ALL** the instructions in this manual carefully.

Definitions:		
<p>USER: Person, organisation or company who or which has purchased or rented the device and is going to use it for the intended purposes.</p>	<p>USER/OPERATOR: Individual who has been authorised by the user to operate the device.</p>	<p>QUALIFIED STAFF: Individuals who have completed a specific course and are therefore able to recognise the hazards arising from the use of this device and are able to prevent them.</p>

6.1 SAFETY STANDARDS



The Manufacturer disclaims any liability for failure to comply with the safety and prevention standards as described below.

The Manufacturer also disclaims any liability for damage caused by improper use of sanitisers and/or alterations carried out without prior authorisation.

- The device must be installed in strict accordance with the instructions contained in this manual.
- Wear suitable accident prevention clothing when installing the device, such as: goggles, gloves, etc. as instructed in standard 686/89/EEC and subsequent amendments.
- While performing installation, operate in full safety, in a clean environment clear of obstructions.
- Comply with the laws in force in the country in which the device is installed, regarding the use and disposal of the packaging and products used for cleaning and servicing the device; you should also observe the recommendations given by the manufacturer of such products.
- **Before switching the device on check the integrity of the various components and of the electrical mains to which it is connected, making sure that it is fitted with a circuit breaker upstream of the power line as shown in this manual.**
- Never insert objects of any kind into the device, as coming into contact with live parts or electrical terminals may cause fires or electric shocks.
- Do not service or clean the device without first unplugging it from the mains.
- Worn or damaged parts must only be repaired or replaced by qualified staff and by following the instructions given in this manual.
- The spare parts must be approved by the Manufacturer.
- In the event of decommissioning or disposing of the device, follow the anti-pollution regulations set out by the country in which the device is installed.
- In doing puncture in walls be sure of not interfere with electric ropes, plumbing and whatever can be damaged.
- Do not pour water or any kind of liquids on the device.

- Place the device so that the power cable cannot be stepped on.
- Do not connect the device to power lines connected to any other electric utilities or devices.
- **Use the type of power supply shown on the label. If you are not sure about the type of power supply available, ask your local retailer or electricity provider for assistance.**
- Do not touch the inside of the device, unless specified otherwise in the instructions contained in this manual.
- Never force the components when assembling; although it is made with high strength materials, the parts of the device can be damaged if handled incorrectly.
- Do not try to perform maintenance work on the device, except where specified in this manual. Opening or removing the outer casing may expose you to dangerous live parts or may involve other risks. All maintenance work must be carried out by authorised staff, except where specified in this manual.
- Unplug the device from the mains and contact qualified staff for assistance in one of the following cases:
 - The device has come into contact with water or liquids of any kind.
 - The device has been exposed to the elements.
 - A malfunction persists despite all the installation and/or maintenance procedures have been performed properly.
- Always connect the generator activation contact. This contact must be normally closed in case of active ionization, and normally open in case of deactivated ionization.



IMPORTANT The installer and the user, when using the JONIX duct device, must take into account and solve all the other types of risk associated with the system. For example, risks arising from foreign bodies getting into the device or risks due to dangerous flammable or toxic gases at high temperature.

6.2 GETTING STARTED



- Check that the various components of the device are fully intact.
- Check that the documentation and any accessories for installation are contained in the package.



- Carry the device in its packaging as close as possible to the installation site.
- Do not rest weights or tools on the device, or place it on an unstable surface.

6.3 CHOOSING THE INSTALLATION SITE



- Do not put the device in places where there are flammable gases, acidic, aggressive and corrosive substances that can damage the various components beyond repair.
- Provide a minimum clearance, in order to install the device and carry out routine and special maintenance.

6.4 INSTALLING THE DEVICE

The device JONIX duct is designed to be secured directly onto the surface in contact with the air to be treated, using specific brackets. Therefore, that surface must be provided with a 185 mm x 145 mm rectangular hole and holes for applying the screws, as indicated in the attached fixing discharges.

Easy to install in any ductwork and with any material.

JONIX duct devices – thanks to their adaptability and to their space-saving designs - can be easily fixed on either side of the duct. All you need is an opening on a wall (in horizontal or vertical position): the device can be fastened using the eyelets supplied as standard.

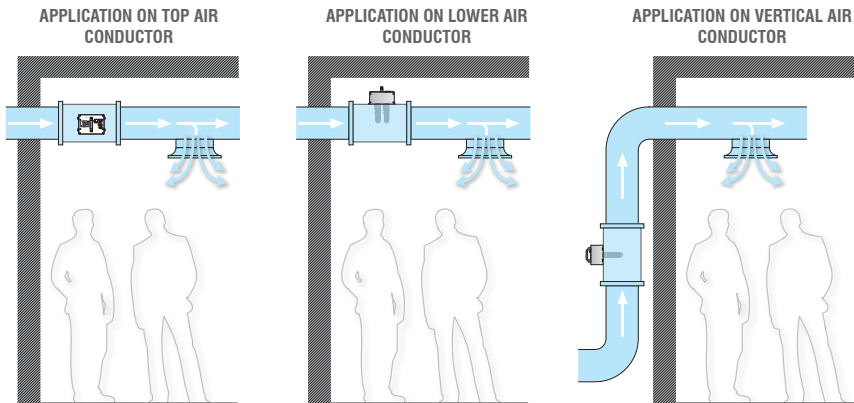

Fastening example of the JONIX duct module on ventilation pipes.

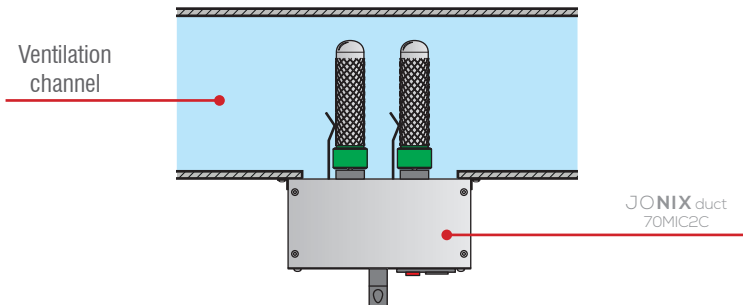

IMPORTANT:

With tissues duct, provide an attachment plenum in installation phase of the JONIX duct device.

6.5 ELECTRICAL CONNECTIONS



ATTENTION! BEFORE STARTING ANY OPERATION, MAKE SURE THAT THE MAIN POWER SUPPLY IS DISCONNECTED!

- The electrical connections must be carried out following the instructions provided in this manual.
- **Make sure that voltage and frequency of the electric line correspond to those provided on the name plate.**



WARNING!

Using power supply that does not meet the requirements requested by the device could resolve in damaging the device or part of it.

- The electrical mains of the JONIX duct device must be used for the device only, there must be no other devices powered by the same power line. Do not use adapters, power strips and/or extension cords.
- Make the connection with cables with a suitable cross-section and in compliance with local standards.
- **The installer must see to it to assemble the device as close to the power disconnecter as possible, according to standards in force and as far as necessary to protect the electrical parts.**

6.6 ELECTRIC POWER SUPPLY

The JONIX duct device leaves the factory fully wired. It only needs to be plugged into the electric mains, 230V/ ~1 / 50Hz + PE. Power must be brought to the socket installed on the module by an IEC 60320 C13 type plug. A residual current device must be installed upstream according to standards in force. The socket on the panel is equipped with a fuse.



ATTENTION!

Wire the connector (supplied) with a cable of suitable double section insulation (F + N + PE). Before making any connections, make sure the mains voltage complies with what is shown on the label.

The ON/OFF switch indicates when the device is powered.

It has also to be provided:

- A four-pole connection cable to the "X2" terminal block to report the signals maintenance/replacement or alarm.
- A six-polar cable connecting to the "X3" terminal block for the on/off command remote shutdown; alarm reset and the Modbus RS 485 serial communication line.

The plugs of these contacts are provided with the form.

6.6.1 Control electronics

JONIX duct devices are made up of electronic control and of actuators: the ionising unity are exposed to airflow. The electronics in the device is prepared to be sent at the central system, in real-time, of an eventual alarm signal in case of failure of the ionisation system. For this reason, it is easy to implement a software interface that can throw on video, from this signal, a request message of maintenance.

The exchange of informations in entrance and in exit is full managed by 2 sockets, one of 6 poles for input and control signals (RS 485) and one of 4 poles for output signals (anomalies signals). For the management and control of the devices, a visualization display has been developed **J-Master¹⁰** (up to a maximum of 10 devices) and a **Jonix NET** remote concentrator (up to a maximum of 30 devices).

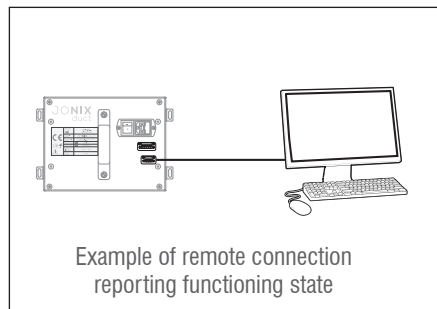
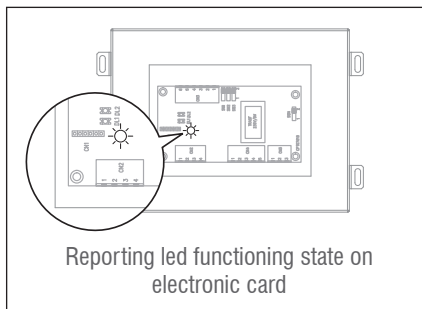
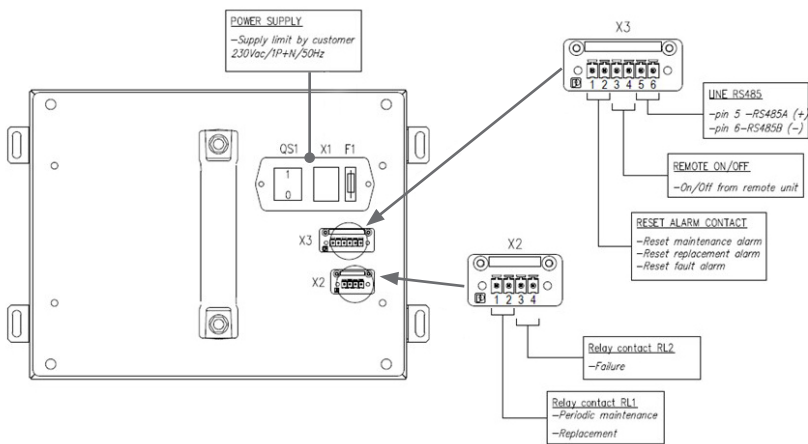

The alarms are split up into type and marked through 2 clean contact usually opened:

1. **RL1 Maintenance alarm periodic/replacement.**

The active periodic maintenance RL1 (flashing 5 sec. on, 2 sec. off) occurs after 7000 hours of operation for new systems, while, for existing systems, where the pollution level of the channels is not known, it is recommended to set 1000 hours to see the initial fouling; the replacement is reported after 14,000 con the activation of RL1 (fixed) and requires the replacement of the generators. Once done the requested operations the relay can be reset through command on serial line or through IN1 entrance. In this last one case you have to apply a short-circuit of 2 seconds.

Two leds, one red and one green, in the electronic card inside the module provide indications of the type of the active alarm.

Red LED LD1	
LED status	DESCRIPTION
LED off	Lack of power.
LED on steady	Board powered in stand-by (ionization OFF).
LED on flashing	Board powered with RL5 relay activated (Ionisation ON).

Green LED LD2	
LED status	DESCRIPTION
LED off	No alarms.
LED on steady	Alarm exceeding the replacement hours threshold.
LED on flashing (6" ON, 26" OFF)	Alarm exceeding the maintenance hours threshold.

It exists a relay that allows to activate or deactivate the ionisation through Modbus protocol. There is a serial line RS485 with Modbus protocol (4800N81) for the programming of the main parameters and the remote diagnosis of the equipment.

The device is controllable and monitorable by using the only serial line.

CONFIGURATION	
Baud Rate	4800
World Length	8
Parity	NONE
Stop Bits	1

The registers with variables are the following:

N°	VARIABLE DEFINITION	UNITY	NOTES	LECTURE (R) / SCRIPTURE (W)
0	Firmware code	-	2	R
1	Firmware version	-	1	R
2	Modbus destination	-	1 (Default)	R / W
3	-	-	-	R
4	-	-	-	R
5	-	-	-	R
6	-	-	-	R
7	-	-	-	R
8	-	-	-	R
9	-	-	-	R
10	-	-	-	R
12	Threshold 1 count hours alarm maintenance (selectable with SW1-1: OFF default 7.000 hours)	Hours	If 0 the control is not active	R/W
13	Alarm count hours maintenance	-	0: not active 1: active (type 0 to reset)	R/W
14	Count hours replacement	Hours	Hours	R
15	Threshold count hours alarm replacement (Default 14.000 hours)	Hours	If 0 the control is not active	R
16	Alarm count hours replacement	-	0: not active 1: active (type 0 to reset)	R/W
17	Pilotage rating Modbus On/Off	-	0: not enabled 1: enabled	R/W
18	Pilotage Modbus On/Off	-	0: not active ionisation 1: active ionisation	R/W
19	-	-	-	R/W
20	Threshold 2 count hours alarm maintenance (selectable with SW1 – 1: ON = 1.000 hours)	Hours	If 0 the control is not active	R/W
21	IN2 enabling for generators activation	-	0: not enabled 1: enabled	R/W
22	IN1 state	-	0: contact open 1: contact closed	R
23	IN2 state	-	0: contact open 1: contact closed	R
24	Current state of generators	-	0: off 1: on	R
25	Percentage count hours maintenance	-	Count hours / active threshold	R
26	Percentage count hours replacement	-	Count hours / active threshold	R
27	Reset count hours maintenance	-	Write 1 to reset count hours	R/W
28	Reset count hours replacement	-	Write 1 to reset count hours	R/W
29	-	-	-	R/W
30	-	-	-	R/W
31	-	-	-	R

6.7 USING THE DEVICE

Fig. 01: Connect the device to the mains using the power cable with suitable cross-section.

Connect the alarm contact to the machine's control system. This contact is normally closed when operating properly and is only triggered when the system detects a fault.

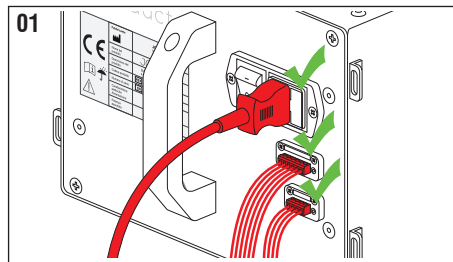

We recommend you to link the contact of input signal and serial interface RS485 (see also paragraph 6.6.1 "Control electronics").

Fig. 02: Once connected to the mains supply, the JONIX duct module is ready to work. In order to turn on the device act on the red switch 0/I turning it to I.

To activate the device close the remote ON/OFF contact on terminal block "X3" (closure of the contact between pins 3-4 of terminal block X3; see specifications in paragraph 6.6.1); you will hear a slight hissing sound coming from the ionising tubes and the corresponding LED will light up, indicating that the unit is switched on.

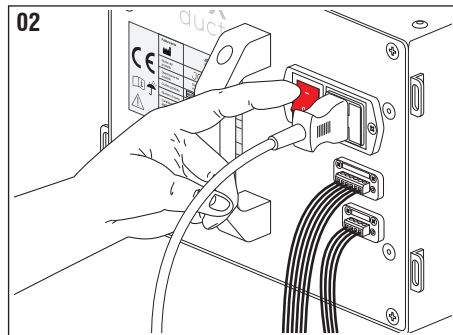

7 - MAINTENANCE

7.1 WARNINGS



BEFORE CARRYING OUT ANY MAINTENANCE OPERATION MAKE SURE THAT THE DEVICE IS NOT AND CANNOT ACCIDENTALLY BE POWERED ELECTRICALLY. YOU MUST THEREFORE UNPLUG THE DEVICE BEFORE CARRYING OUT ANY MAINTENANCE.

- It is the duty of the user to perform all the maintenance operations on the device listed below.
- If you experience a malfunction, unplug the device from the mains and contact qualified staff (retailer, the Manufacturer).
- Only trained and qualified personnel can perform maintenance operations.



Use work gloves to protect your hands when performing maintenance.

The frequency of the operations to be performed to ensure proper maintenance of the device JONIX duct depends mainly on the quality of the treated air. Air can be especially harmful for condensers when it contains polluting or aggressive substances such as:

- Industrial flue gas
- Sale
- Chemical smoke
- Heavy powders



By coming into contact with the inside or outer surfaces of the device by means of the air flow or by direct exposure, these substances can lead to a structural and functional failure of the device and of its performance as time passes and without proper, systematic maintenance.

7.2 ROUTINE MAINTENANCE

The JONIX duct device requires a small amount of maintenance consisting in regularly cleaning the glass and outside mesh of the condenser.

The device signals the need for maintenance of the generators, by means of a special alarm contact, every 7000 hours of operation.

7.2.1 Cleaning the Ionising Tubes

Fig. 03: Switch off the ionising module JONIX duct by turning the luminous On/Off switch to **0**.

Remove the plug connected to the mains and other plugs from the JONIX duct module.

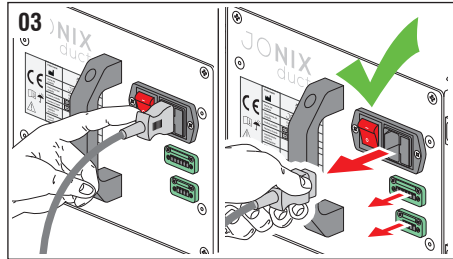

Fig. 04: Unscrew the four screws which, by means of the brackets, secure the module to the wall and pull it out by the handle.

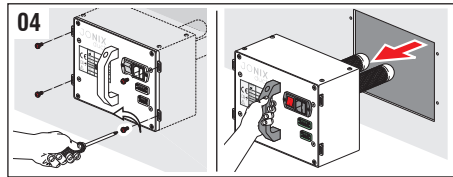

Fig. 05: Gently unscrew the tubes, using the green plastic base. If you have trouble, first pull off the outer mesh.



If the operation is difficult to perform, pull slightly the earthing spring so that it is not in contact with the surface of the tube.

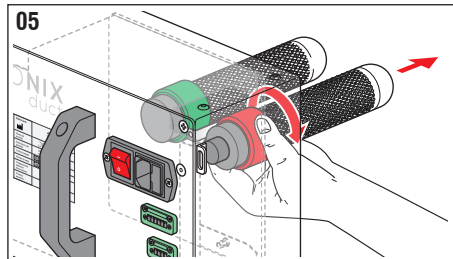
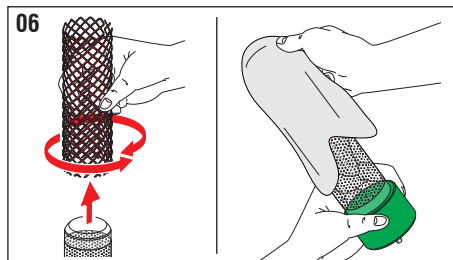

Fig. 06: Pull off the outer mesh from the tube if you have not already done so in the previous point.



If this is difficult to do, turn the mesh around the glass while pulling to remove it.



Clean the glass using a damp cloth.



Check that the tube is in good conditions: there must not be any cracks or other damage; otherwise it must be replaced. As soon as you notice a whitish layer on the perforated metal plate inside the glass it means that the ionising tube needs replacing.

The tubes must usually be replaced within 18 months of use.

Fig. 07: Wash the mesh under running hot water and dry it thoroughly with a cloth.



Do not put back the mesh on the ionising tube if it is even partially wet.

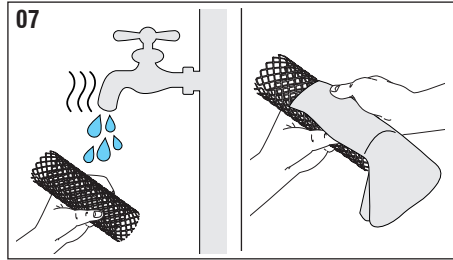

Fig. 08: Put the outer metal mesh back on the glass tube so that it fully overlaps the internal plate.



In any case ensure a minimum distance of at least 3 mm from the base of the tube.

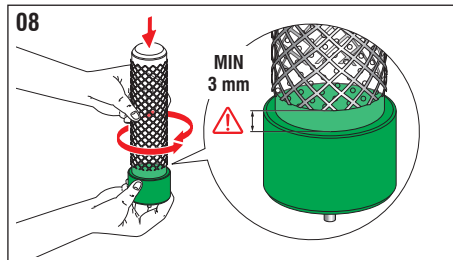

Fig. 09: Gently screw the ionising tube holding on to the base (green part). If the operation is difficult to perform, pull slightly the earthing spring so that it is not in contact with the surface of the tube.

ATTENTION: do not overtighten the screw after reaching its end stop.



Check that the earthing spring is in contact with the outer mesh once the ionising tubes have been screwed back into place. Otherwise contact the manufacturer.

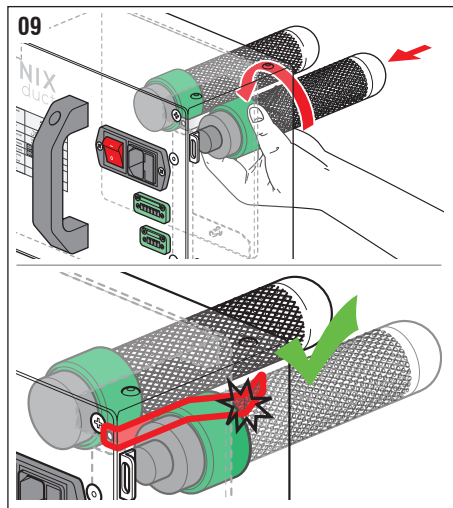

Fig. 10: Reposition the device JONIX duct by inserting the ionising tubes horizontally into the specific hole using the handle and screw in the 4 screws which secure the brackets to the wall.

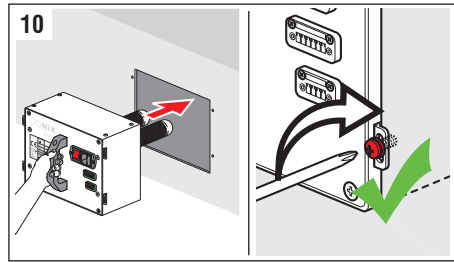
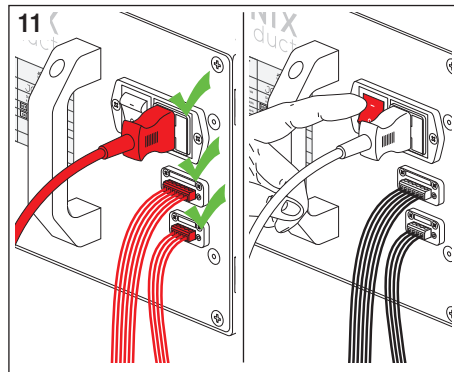

Fig. 11: Reinsert the power supply plug and all other plugs in the appropriate sockets of the JONIX duct module. Switch on the module by turning the On/Off switch to I. Verify the functioning of the device, it has to be hear a light sizzle coming from the tubes.



Reset the alarm signal by closing the contact for at least 5 seconds between pins 1-2 of terminal block X3 (see paragraph 6.6.1).



Failure to clean the ionising tubes leads to a drop in system performance.

7.2.2 External cleaning of the equipment

Clean the outside of the device with a damp cloth.



Do not use liquid cleaners or sprays, soap or the like.

7.3 SPECIAL MAINTENANCE

The only part that is subject to wear is the **ionising tube**, whose performance deteriorates over time.

When signs of wear appear, it is necessary to replace the component. They are evident with the appearance of oxide in the condenser internal mesh that will make it whitish, and that will render the glass opaque. The device will signal the need of replacement of the component after 14000 hours of operation.

7.2.1 Replacing the Ionising Tubes

Fig. 12: Switch off the ionising module JONIX duct by turning the luminous On/Off switch to **0**. Remove the plug connected to the mains and other plugs from JONIX duct module.

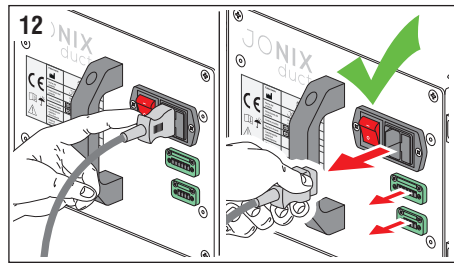

Fig. 13: Unscrew the four screws which, by means of the brackets, secure the module to the wall and pull it out by the handle.

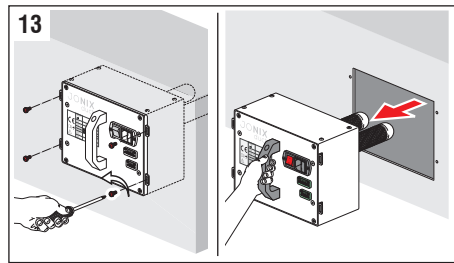

Fig. 14: Gently unscrew the tubes, **using the green plastic base**. If you have trouble, first pull off the outer mesh.



If the operation is difficult to perform, pull slightly the earthing spring so that it is not in contact with the surface of the tube.

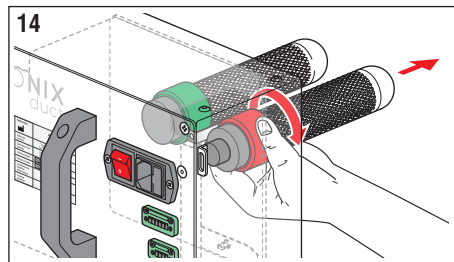

Fig. 15: Screw delicately the ionising tube holding on to the base (green part). If the operation is difficult to perform, pull slightly the earthing spring so that it is not in contact with the surface of the tube.

ATTENTION: do not overtighten the screw after reaching its end stop.



Check that the earthing spring is in contact with the outer mesh once the ionising tubes have been screwed back into place. Otherwise contact the manufacturer.

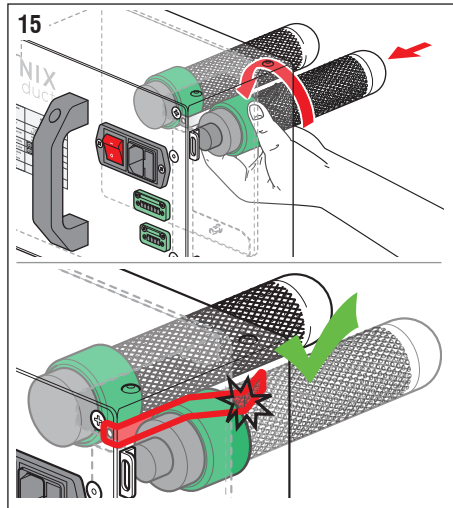

Fig. 16: Reposition the device JONIX duct by inserting the ionising tubes horizontally into the specific hole using the handle and screw in the 4 screws which secure the brackets to the wall.

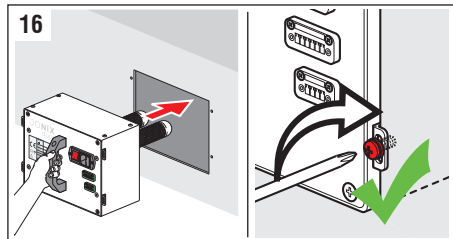

Fig. 17: Reinsert the power supply plug and all other plugs in the appropriate sockets of the JONIX duct module.

Switch on the module by turning the On/Off switch to I.

Verify the functioning of the device, it has to be hear a light sizzle coming from the tubes.



Reset the alarm signal by closing the contact for at least 5 seconds between pins 1-2 of terminal block X3 (see paragraph 6.6.1).

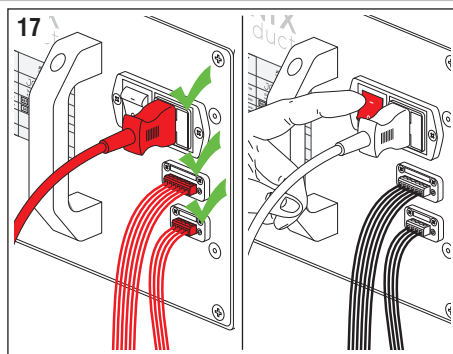

Failure to replace the ionising tubes leads to a decrease in system performance until they actually break. From that moment on, they will have no more effect on treated air.

8 - OPERATIONAL CHECK AND TROUBLESHOOTING

This section summarises the most common problems that may arise when using the unit. Before contacting customer services, carry out the checks listed below.

PROBLEM	POSSIBLE CAUSE	SOLUTION
The switch does not light up when set at I.	The unit is not powered.	Check that the plug is connected to the mains power socket.
		Verify that the plug is connected to the power supply socket on the module.
		Verify that the socket where the device is connected works.
		Verify the presence of power in distribution system.
		Verify that the protection fuse isn't burnt.
The alarm contact 1 notes the presence of a malfunctioning and the spy is on. The green LED of the internal electronic card emits an intermittent flashing.	The system detects the need of cleaning the ionising tube.	Follow the cleaning of the ionising tubes procedure in paragraph 7.2.1.
The alarm contact 1 notes the presence of a malfunctioning and the spy is on. The green LED of the internal electronic board remains steady.	The system detects the need of replacing the ionising tube.	Follow the replacement of the ionising tubes procedure in paragraph 7.3.1.
Power supply present, no malfunction, but the ionization is not active.	Ionization activation contact open.	Check that the ionization activation contact is normally closed.



In the event that you experience a malfunction other than those described above contact qualified staff (retailer, Manufacturer).

Unplug the device from the mains and contact qualified staff for assistance even in the event of one or several of the cases below:

- The power cable is damaged or worn.
- The plug is damaged or worn.
- Water or liquid has been poured onto the device.
- In the event that there is a malfunction despite all the installation procedures have been carried out properly.

9 - DISPOSAL

When JONIX duct devices are no longer used they must be disposed of in compliance with the regulations in force in the country of installation. The unit consists of the following materials:

- Stainless steel.
- Aluminium.
- Galvanized iron.
- Glass.
- Nylon.
- Plastic.
- Paper and Cardboard.
- Wood.



WASTE ELECTRICAL AND ELECTRONIC EQUIPMENT MANAGEMENT

This product falls within the application scope of the Directive 2012/19/EU concerning the management of waste electrical and electronic equipment (WEEE). Equipment must not be disposed of with household waste as it is made of different materials that can be recycled at special facilities. Please inquire through your municipal authorities as to the location of the eco-friendly waste management sites where waste can be received for disposal and its subsequent recycling as recommended. Furthermore, please note that, when an equivalent appliance is purchased, the seller is expected to collect free of charge the old product to be disposed of. The product is not potentially dangerous for human health and the environment, as it does not contain any harmful substances according to the Directive 2011/65/EU (RoHS), but if disposed of freely in the environment, it might adversely affect the ecosystem.

Read the instructions carefully before using the equipment for the first time. It is strongly recommended not to use the product for any purpose other than that for which it was designed, to prevent the risk electric shock if the product is used incorrectly.

ATTACHMENTS

OVERALL DIMENSIONS JONIX duct 70MIC2C

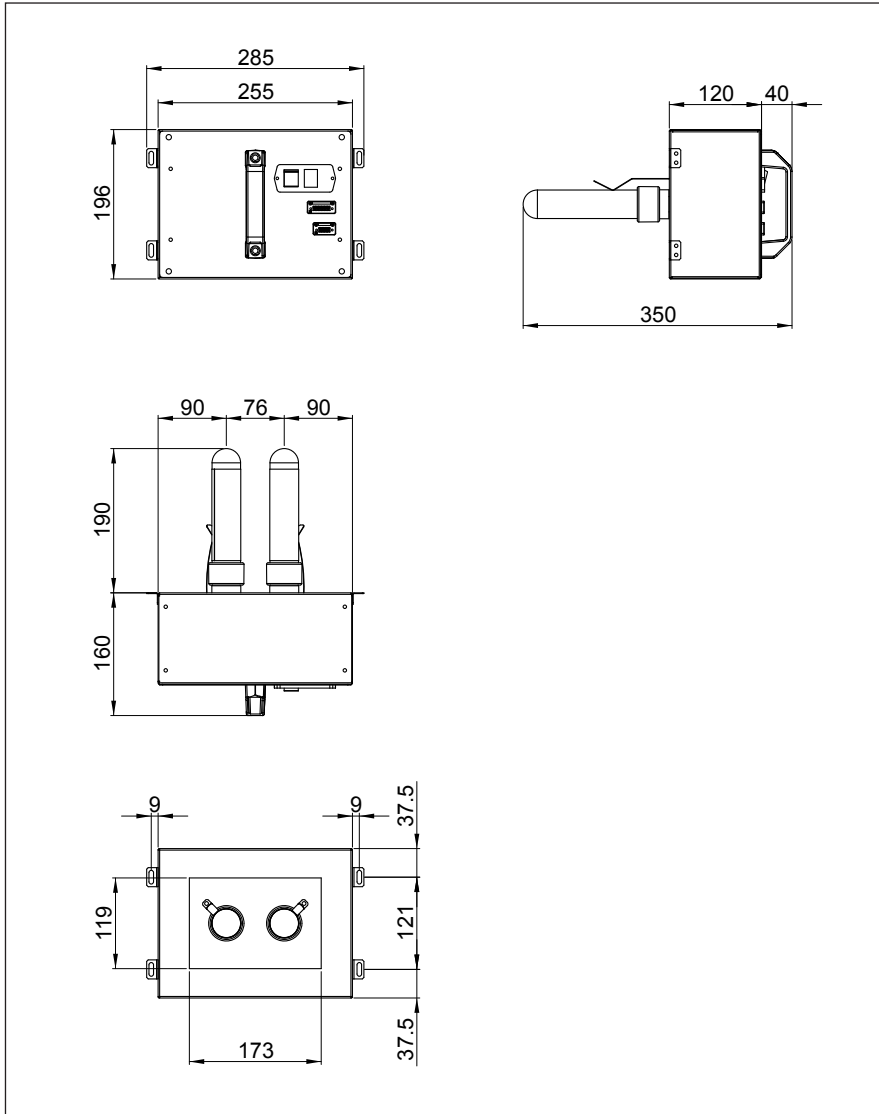

OVERALL DIMENSIONS JONIX duct 70MIC4C

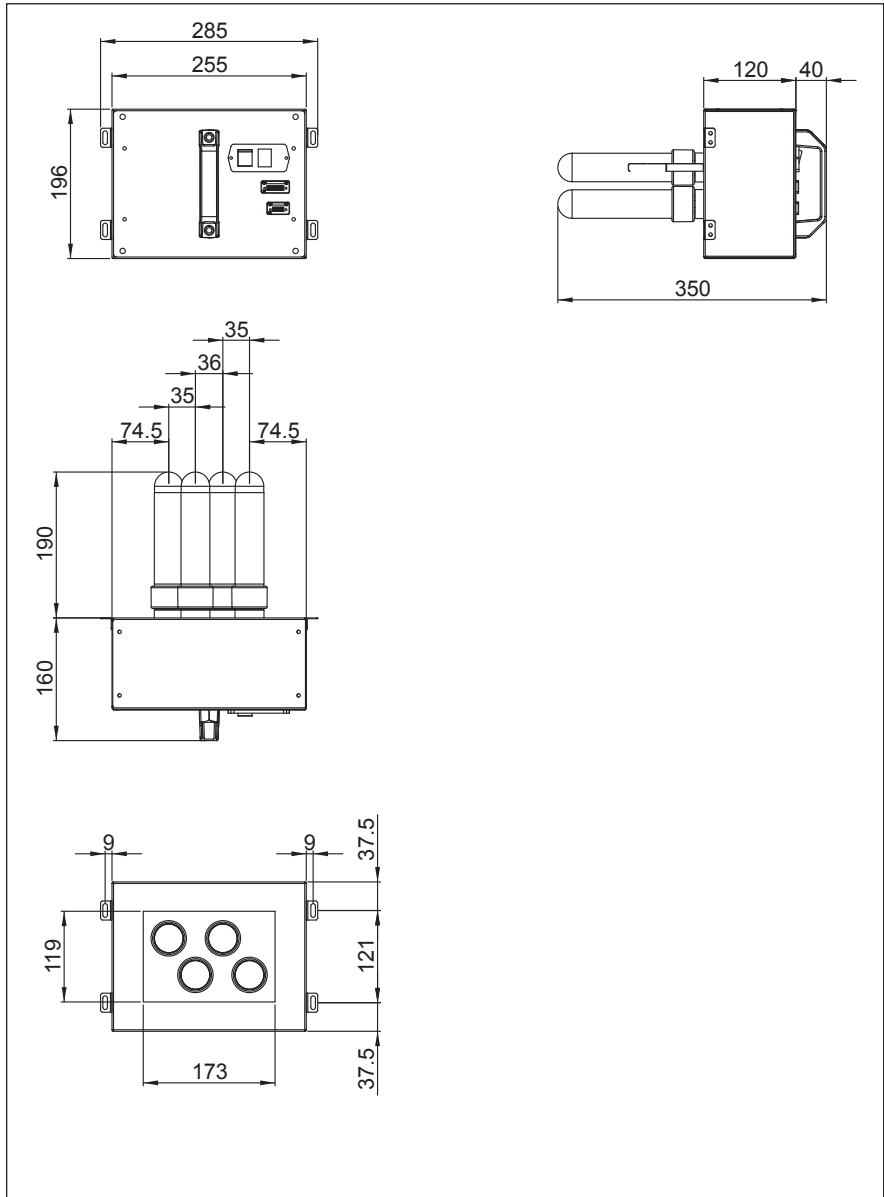

OVERALL DIMENSIONS JONIX duct 70MIC2F

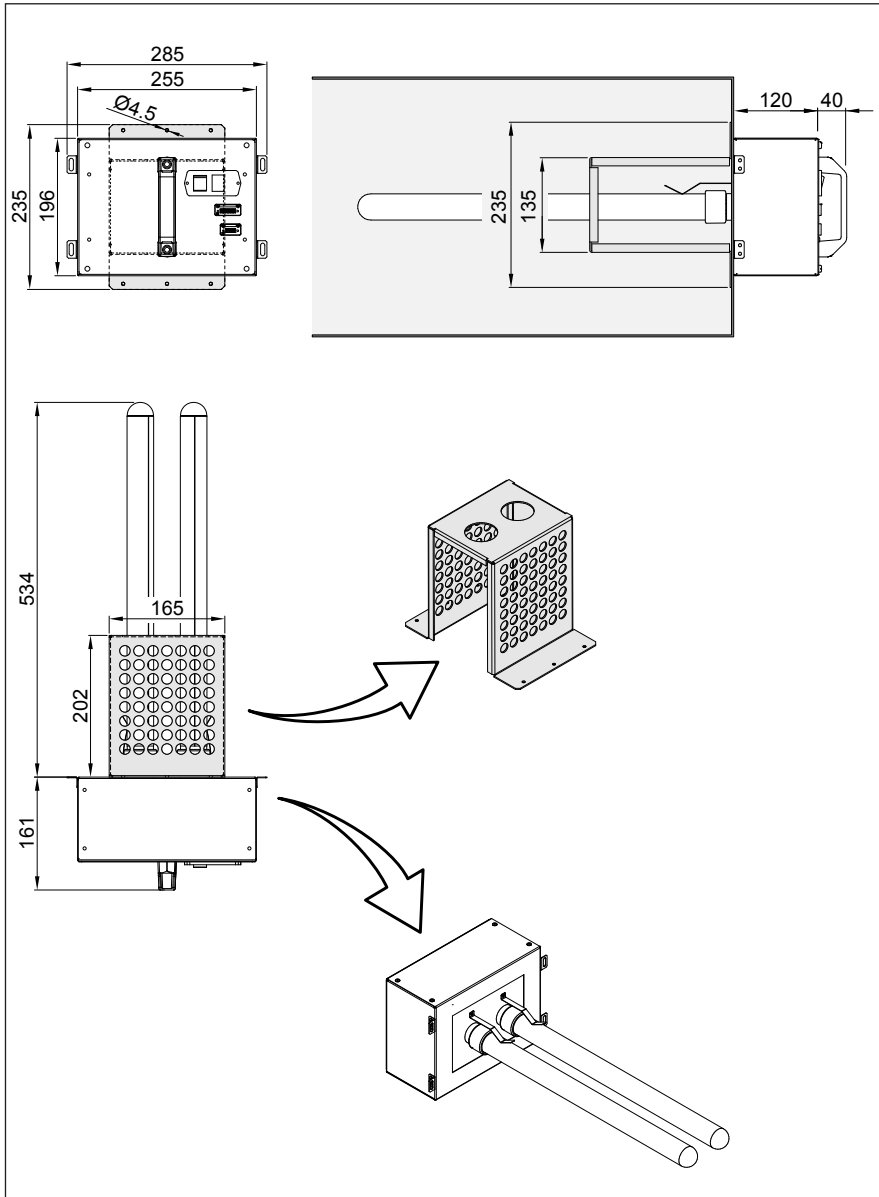

SPECIFICATIONS FOR INSTALLATION JONIX duct 70MIC2F

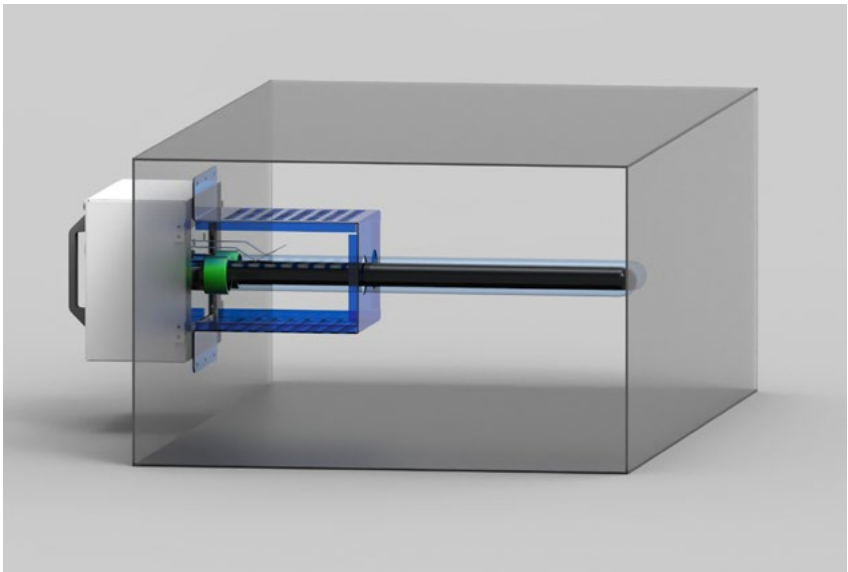
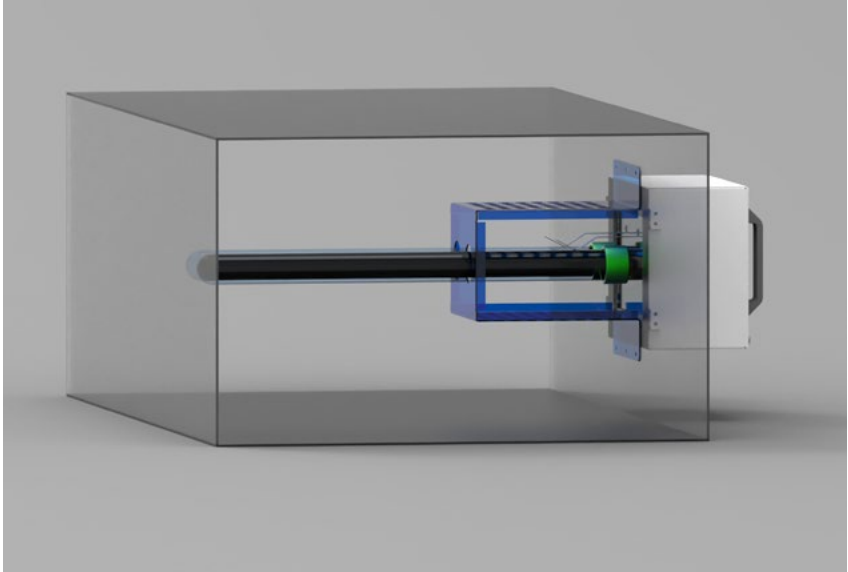

OVERALL DIMENSIONS JONIX duct 70MIC4F

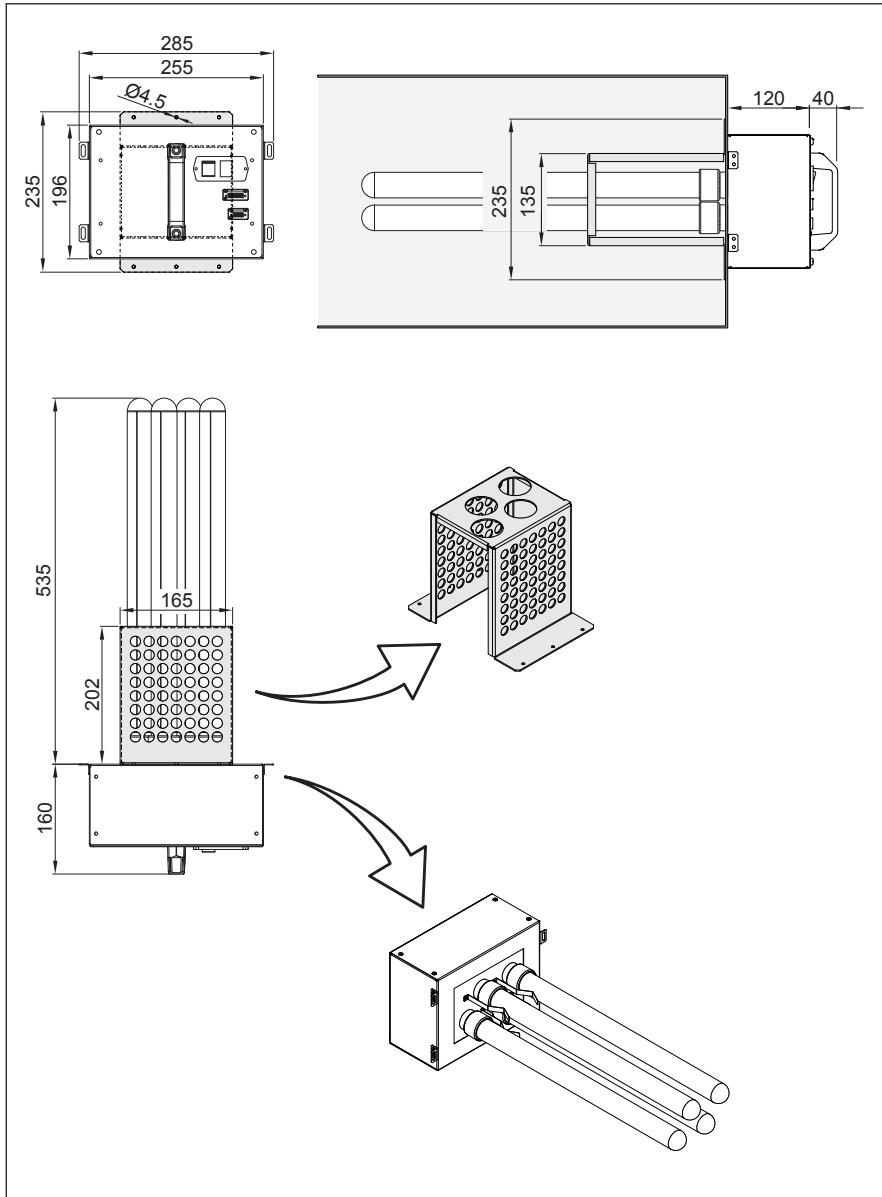

SPECIFICATIONS FOR INSTALLATION JONIX duct 70MIC4F

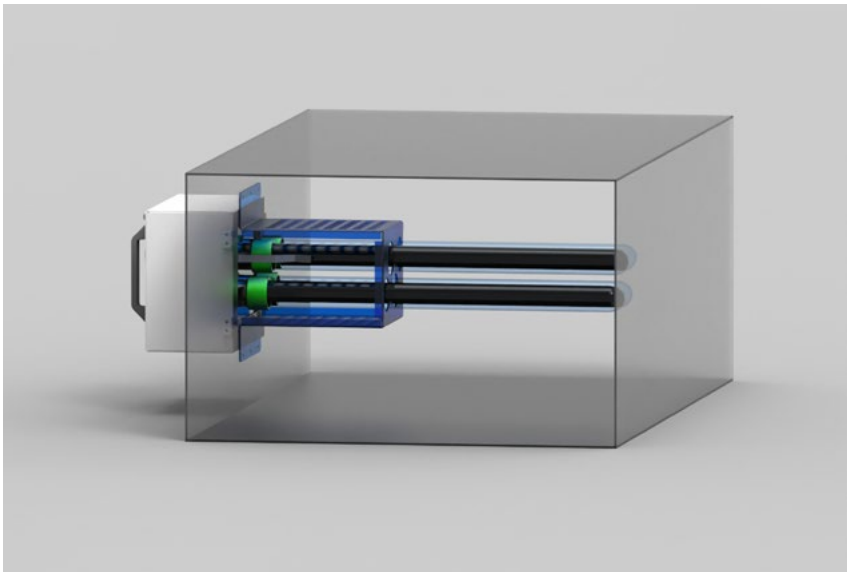
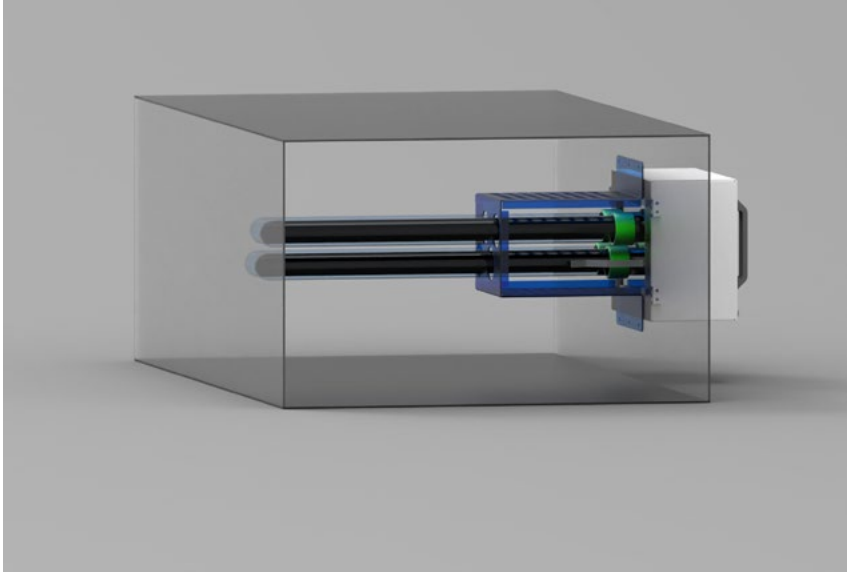

TEMPLATE OF CUT ON METAL CHANNEL FOR INSTALLATION JONIX duct 70MIC2C

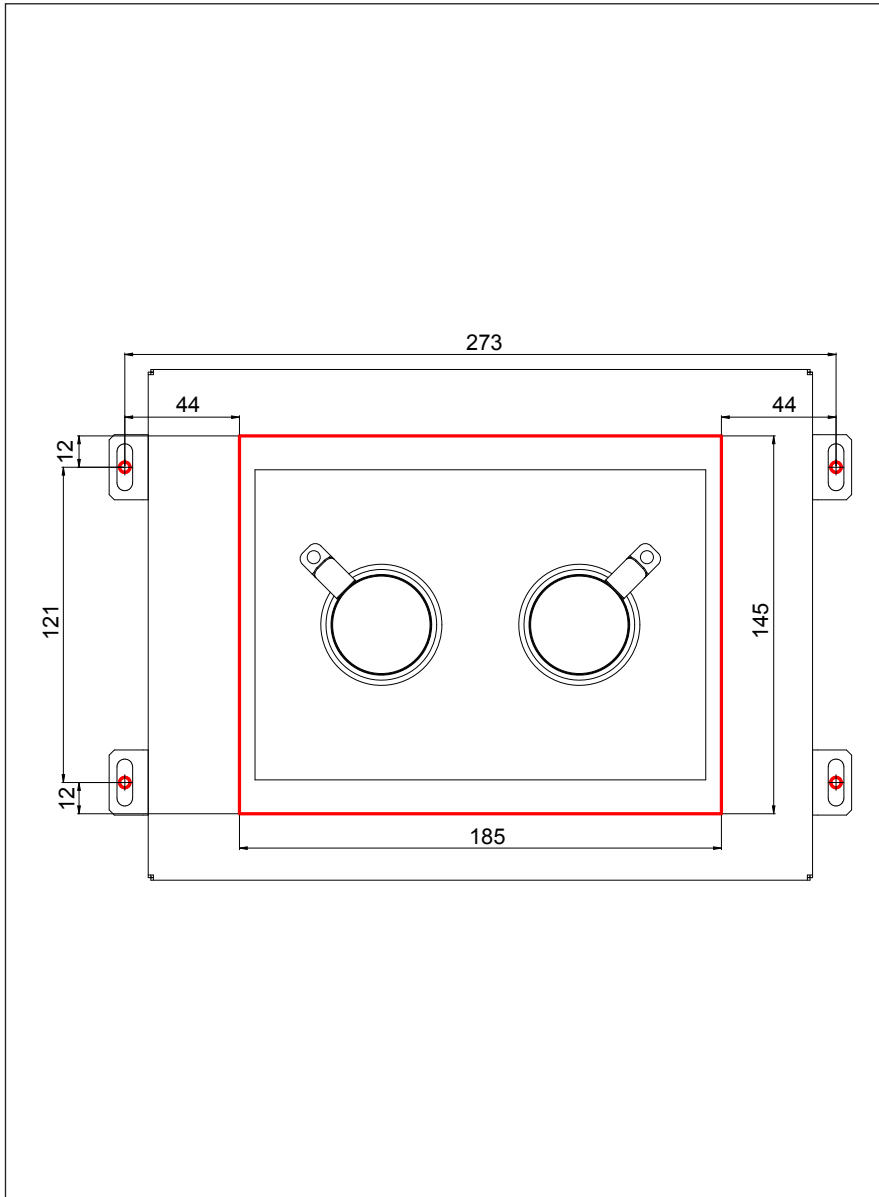

TEMPLATE OF CUT ON METAL CHANNEL FOR INSTALLATION JONIX duct 70MIC4C

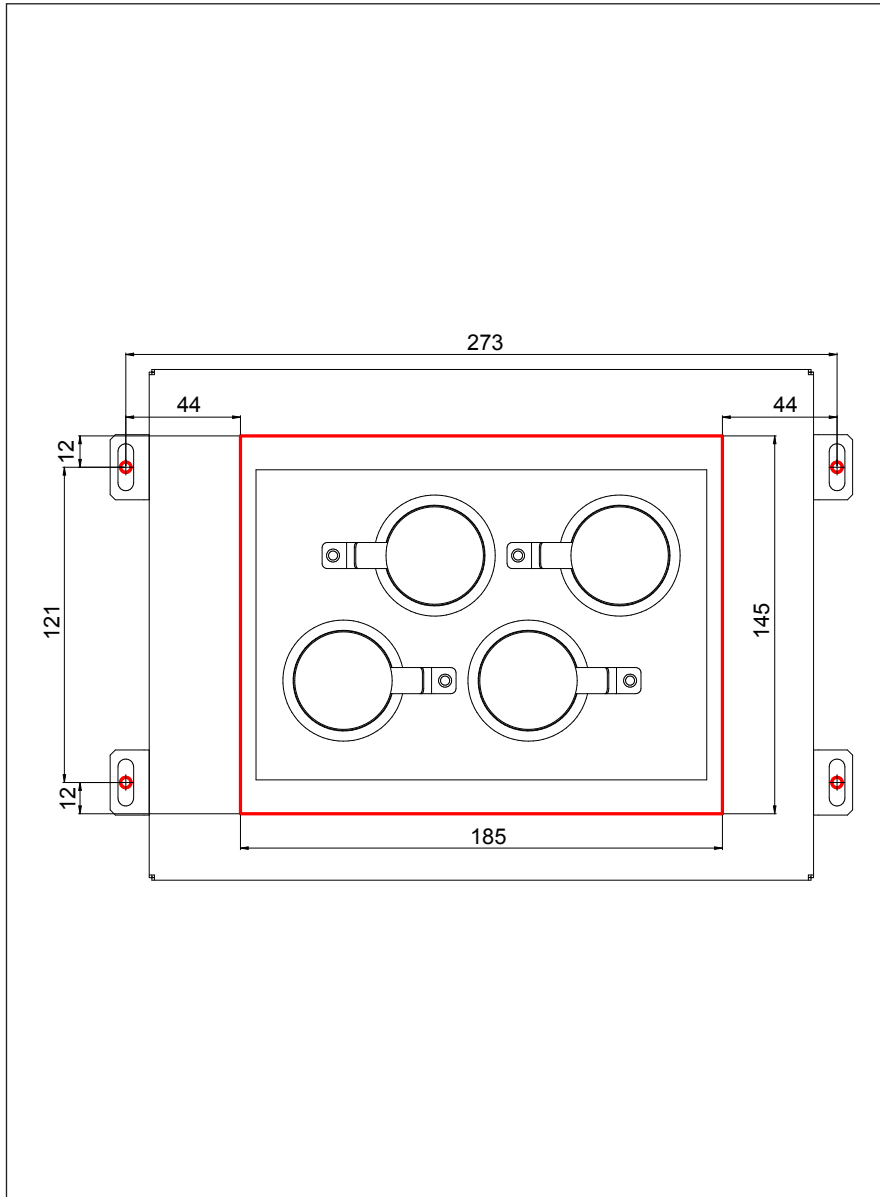

TEMPLATE OF HOLE FIXING SUPPORT BRACKET JONIX duct 70MIC2F

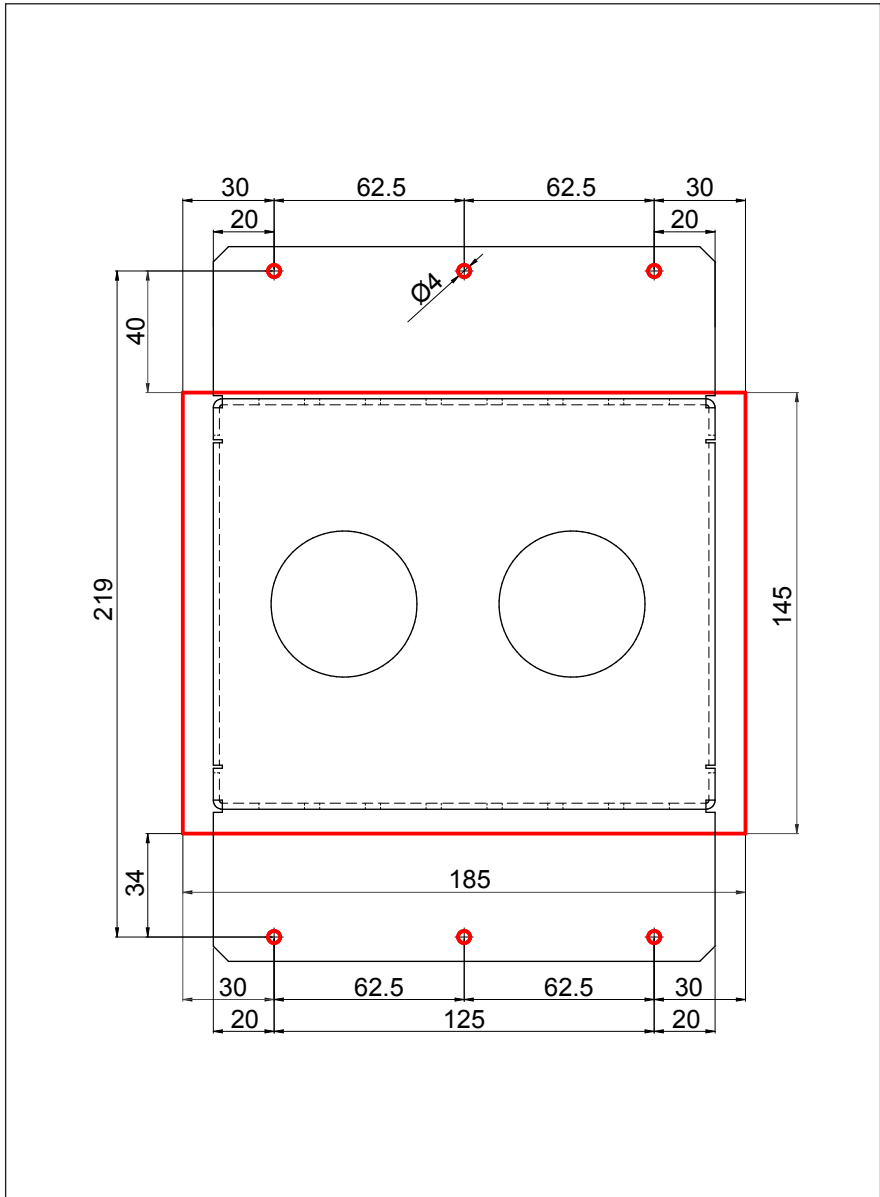

TEMPLATE OF HOLE FIXING SUPPORT BRACKET JONIX duct 70MIC4F

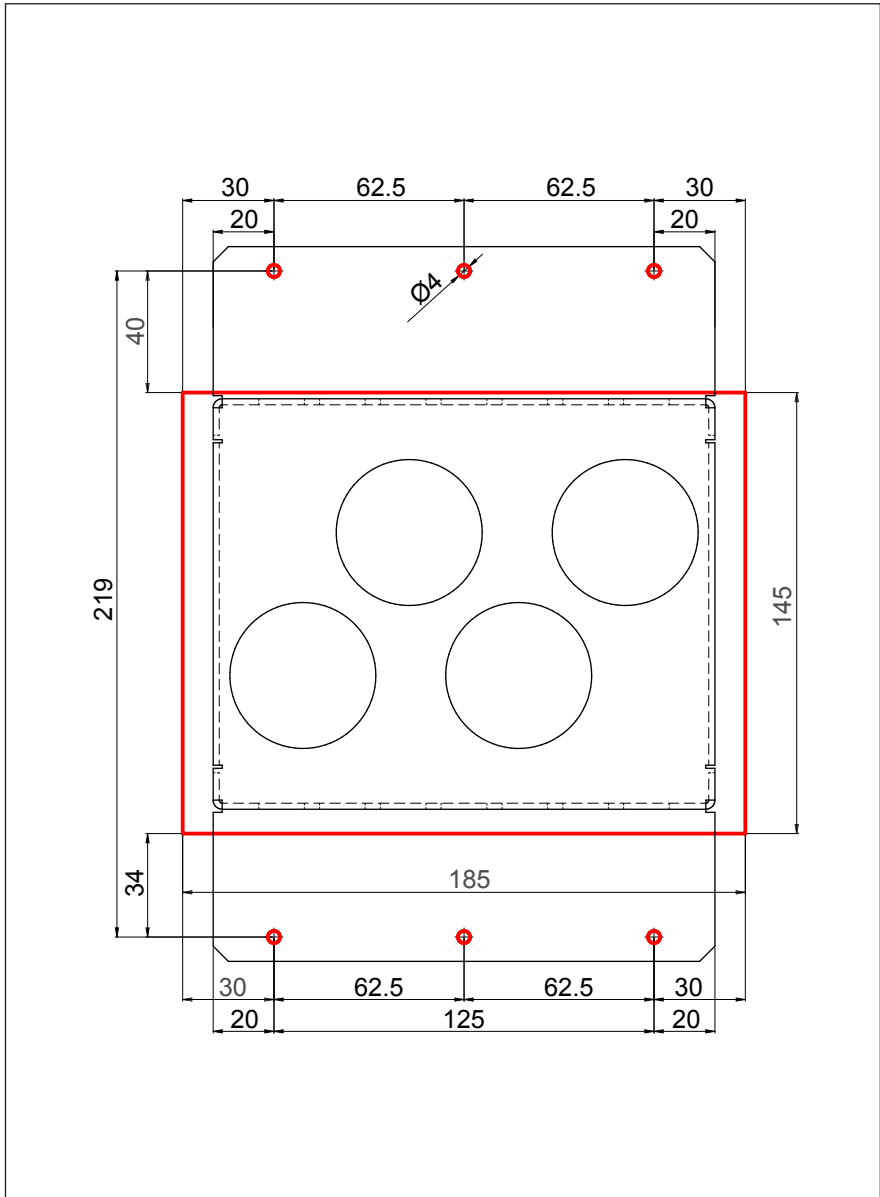

NOTES

.....

.....

.....

.....

.....

.....

.....

.....

.....

.....

.....

.....

.....

.....

.....

.....

.....

.....

.....

.....

.....

.....

.....

.....

.....

.....

.....

.....

.....

.....

.....

.....

.....

.....

.....

.....

.....

.....

.....

.....

.....

.....

jonixair.com

JONIX Spa
Benefit Corporation

info@jonixair.com
Certified mail: jonixsr1@legalmail.it



Registered Office:
Viale Spagna 31/33
35020 Tribano (PD) - Italy
Ph. +39 049 9588511
Fax +39 049 9588522

Operational Headquarters:
Via dell'Artigianato, 1
35020 San Pietro Viminario
(PD) - Italy
Ph. +39 0429 760311

**Research and Development
Headquarters:**
Via Tegulaia 10/b
56121 Pisa - Italy
Ph. +39 050 985165