

## J-Master<sup>10</sup>

USE AND MAINTENANCE MANUAL  
(ENABLED TECHNICIAN)

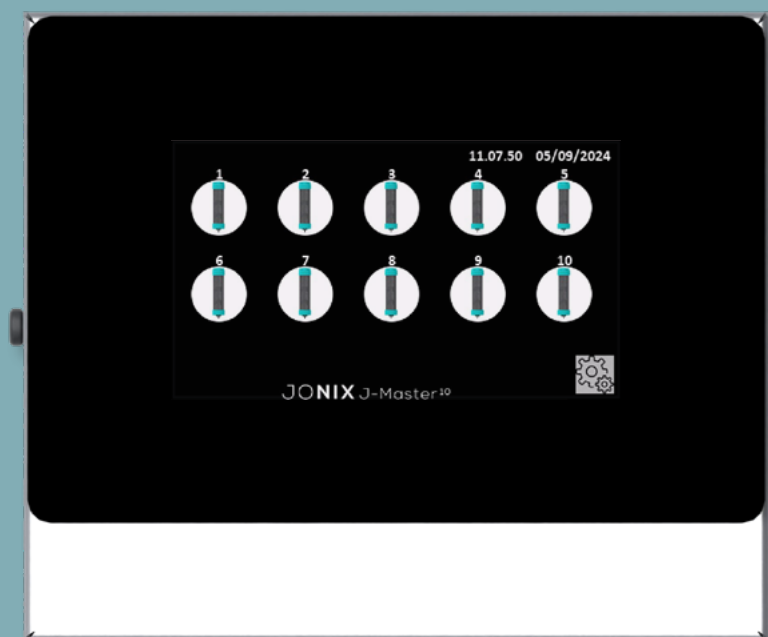

DEVICE FOR REMOTE MANAGEMENT  
OF IONIZING MODULES



These instructions are translated from Italian (the original language).

JONIX S.p.A. reserves every right concerning this manual, including the right to make any necessary change or improvement to its products and to the manual at any time and without notice. It is forbidden to reproduce in full or in part this manual without JONIX S.p.A.'s consent.

Thank you purchasing the **J-Master<sup>10</sup>** device.

This manual contains the information and all that is required for the transportation, installation, use and maintenance of the device for remote management of ionizing modules **J-Master<sup>10</sup>**.

Improper installation of the device and/or failure to comply with the instructions in this manual, may invalidate the warranty that the Manufacturer issues for its products.

The Manufacturer is not liable for any direct and/or indirect damage caused by incorrect installation or damage caused by the units installed by inexperienced and/or unauthorised staff. At the time of purchase, check that the device is intact and complete.

The Manufacturer declines any liability in case of personal injury or property damage resulting from any improper use of the device or from the failure to observe the use and safety instructions specified in this manual. In any such case, any warranty claim will be void.

Any complaints must be submitted in writing within **8 days** of receiving the goods.

## TABLE OF CONTENTS

<b>1 - GENERAL INFORMATION</b>	<b>5</b>
1.1 - SERIAL NUMBER PLATE	5
1.2 - LIABILITY	5
1.3 - SYMBOLS	6
<b>2 - WARNINGS AND GENERAL PROHIBITIONS</b>	<b>6</b>
<b>3 - OPERATING SYSTEM J-Master<sup>10</sup></b>	<b>8</b>
3.1 - INTRODUCTION	8
3.2 - SUPERVISION AND CONTROL SYSTEM	8
<b>4 - TECHNICAL DATA</b>	<b>9</b>
4.1 - COMPONENT DESCRIPTION	9
4.1.1 - Technical features	9
4.2 - SPARE PARTS AVAILABLE ON ORDER	9
<b>5 - RECEPTION, TRANSPORT AND STORAGE</b>	<b>10</b>
5.1 - PACKAGING	10
5.2 - HANDLING AND TRANSPORT	10
5.3 - INSPECTION UPON RECEPTION	10
5.4 - STORAGE	10
5.5 - HANDLING DEVICE IN OPERATING CONDITIONS	10
<b>6 - INSTALLATION AND COMMISSIONING</b>	<b>11</b>
6.1 - SAFETY STANDARDS	11
6.2 - GETTING STARTED	12
6.3 - CHOOSING THE INSTALLATION SITE	12
6.4 - INSTALLING THE DEVICE	13
6.5 - ELECTRICAL CONNECTIONS	13
6.6 - ELECTRIC POWER SUPPLY AND CONTROL SIGNALS	14
<b>7 - User Interface</b>	<b>16</b>
<b>8 - Maintenance Technician Interface</b>	<b>20</b>
<b>9 - SuperAdministrator Interface (Only for enabled technicians)</b>	<b>26</b>
<b>10 - MAINTENANCE</b>	<b>33</b>
<b>11 - OPERATIONAL CHECK AND TROUBLESHOOTING</b>	<b>34</b>
<b>12 - DISPOSAL</b>	<b>35</b>
<b>ATTACHMENTS</b>	<b>36</b>
OVERALL DIMENSIONS J-Master <sup>10</sup>	36

## 1 - GENERAL INFORMATION

### 1.1 SERIAL NUMBER PLATE

The equipment described in this manual is provided with a plate containing the equipment and Manufacturer data:

The **J-Master<sup>10</sup>** device is in compliance with Directives 2011/65/UE, 2014/30/UE, 2014/35/UE and subsequent amendments.

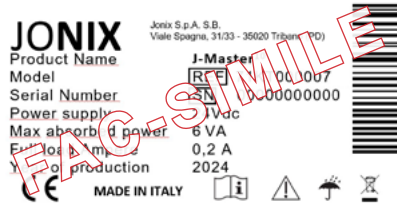

### IMPORTANT WARNING

**The J-Master<sup>10</sup> device is designed and built for the remote management of Jonix equipment; the installation of the same must be carried out within civil environments.. Using the device for purposes other than those intended and that do not comply with those described in this manual, will immediately relieve the manufacturer and its distributors from any direct and/or indirect liability.**

### 1.2 LIABILITY

Failure to comply with the instructions contained in this Use and Maintenance Manual releases JONIX S.p.A. from any liability. For any data not included or not deducible from the following pages it is recommended to contact the manufacturer at the operational headquarters

JONIX S.p.A.  
Via dell'Artigianato, 1  
35020 San Pietro Viminario - PD - Italy  
<http://www.jonixair.com>

In particular, if the maintenance of the device is carried out in a manner that does not comply with the instructions provided, or in any case in such a way as to compromise its integrity or modify its characteristics, JONIX S.p.A. will be relieved of any responsibility regarding the safety of persons, property, animals and the faulty operation of the devices.

### 1.3 SYMBOLS

Please pay utmost attention to the following symbols and their meaning. They emphasise specific information, such as:



**WARNING:** It refers to integrations or suggestions concerning the proper use of the device.



**HAZARD:** It refers to dangerous situations that may result from the use of the device, in order to ensure personal safety.



**FORBIDDEN:** This symbol refers to operations that must be avoided under any circumstances, and hence forbidden.



**VOLTAGE HAZARD!**

Do not open or remove any doors or protections before disconnecting the voltage supply.



**WARNING!**

It is mandatory to use protective gloves.



**WASTE FROM ELECTRICAL AND ELECTRONIC EQUIPMENT.**

The crossed-out wheeled bin symbol on the equipment label indicates that the equipment is compliant with the Waste Electrical and Electronic Equipment (WEEE) Directive. Disposing of the equipment freely in the environment or illegally disposing of the equipment are punishable by law.

## 2 - WARNINGS AND GENERAL PROHIBITIONS



This instruction manual is an integral part of the device and therefore must be kept carefully and must ALWAYS accompany the device, even in the event that it is sold to another owner or user or transferred to another facility. In the event that it is damaged or lost contact JONIX S.p.A. for another copy or download the document from the QR code on the device.



Repairs and maintenance work must be carried out by JONIX S.p.A. authorised staff or by qualified staff according to the provisions set out by this manual. Do not alter or tamper with the device as it can lead to hazards and the manufacturer of the device shall not be liable for any damage caused.



After removing the packaging check that the contents are intact and complete. In the event of a noncompliance please contact the Company that sold you the device.



When installing, commissioning and operating this product, it is mandatory to observe the requirements and instructions specified in this manual.



JONIX S.p.A. disclaims any liability for damage caused to people, animals or property due to installation, adjustment and maintenance errors or by improper use.

Please note that the use of products that require electricity, involves the observance of some crucial safety rules such as:



This device is not intended for use by people (including children) with reduced physical, mental or sensory capabilities or without experience and knowledge, unless they are supervised or are given instructions to use the appliance by a person responsible for their safety. Take suitable precautions to prevent children from playing with the device.



Do not touch the device if you are barefoot and with parts of the body that are wet or damp.



Do not pull, detach or twist the electrical wires coming out of the device, even when it is disconnected from the mains.



Do not stand, sit and/or rest any type of object on the device.



Do not spray or throw water or other liquids directly onto the device.



Do not open the panels for accessing the internal parts of the device without having first turned the system switch to "OFF".



Not dispose of or leave the packaging materials within reach of children because it can be potentially dangerous.

## 3 - OPERATING SYSTEM J-Master<sup>10</sup>

### 3.1 INTRODUCTION

---

**J-Master<sup>10</sup>** is a software that is installed on a 4.3" touch screen display to be positioned on the wall using a dedicated container. This software is used to view the operating status, the wear of the generators and to manage the activation/deactivation of maximum 10 devices equipped with a new generation management board (JX11000042).

The software can be viewed/used remotely, on a local network, using a PC with a specific VNC program.

### 3.2 SUPERVISION AND CONTROL SYSTEM

---

**J-Master<sup>10</sup>** combined with the JX11000042 electronic boards inside the devices (such as duct, steel, etc.) constitutes the supervision and control system. The communication between **J-Master<sup>10</sup>** (Master's Module) and the various devices with remote control card JX11000042 (Slave modules) will take place via an RS485 serial line with Modbus protocol.

There are 2 different control modes available:

- **Stand Alone:** in this mode the device is controlled by an external clean contact, which can be interfaced with other equipment present in the building. By setting this mode, the display will not control the device, it will only be able to see its status (on/off), working hours, interventions to be performed and reset the parameters after the interventions.
- **Modbus:** in this mode the devices are completely controlled, displayed and managed by **J-Master<sup>10</sup>**, with the possibility of setting operation in daily/weekly time slots and of combining the operation of the devices at different times.

The software allows the devices to be controlled in both Stand Alone and Modbus mode in the same system. The change of control mode of the devices (from Stand Alone to Modbus and vice-versa) is always modifiable. However, the operation must be performed by the company Jonix spa or by an authorised installer.

## 4 - TECHNICAL DATA

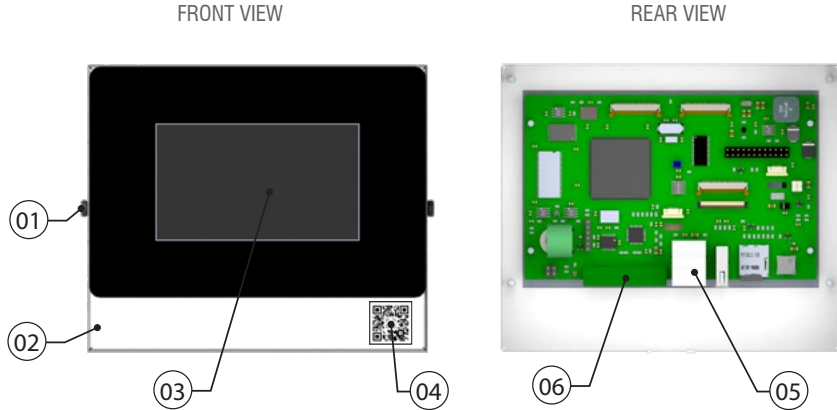

### 4.1 COMPONENT DESCRIPTION

01 Opening/closing box screws	04 QR code label user and maintenance manual
02 Display box	05 RJ45 connection port
03 Display touch screen 4.3"	06 Terminal block for power supply and signal connection

#### 4.1.1 Technical features

Model	Article	Dimensions (LxPxH) [mm]	Power Supply	Connectable Devices	Max power absorption [W]	Weight [Kg]
J-Master <sup>10</sup>	71KT000007	168 x 137 x 33	24Vdc	1 ÷ 10	0,2	0,65

### 4.2 SPARE PARTS AVAILABLE ON ORDER

Code	Description	Notes
JX40000022	POWER SUPPLY 24Vdc 0,63A	1 Power supply J-Master <sup>10</sup>
JX40000080	DISPLAY 4,3" PUZZLE+RJ45	1 Display 4,3"

## 5 - RECEPTION, TRANSPORT AND STORAGE

### 5.1 PACKAGING

J-Master<sup>10</sup> and its accessories are delivered in specific protective packaging and must remain intact until they are assembled. The materials that were not installed for technical requirements are supplied with suitable enclosure secured to the inside or outside of the device itself. The package includes:

- N° 1 J-Master<sup>10</sup> device.
- N° 1 10-pin connector for power and signals.
- N° 1 power supply 24Vdc 0,63A.
- Operating and maintenance manual.
- Declaration of Conformity.
- Warranty conditions.

### 5.2 HANDLING AND TRANSPORT



To handle the device use appropriate means, depending on the weight, as required by Directive 89/391/EEC and subsequent amendments.



Please take great care while unloading and positioning the devices, to prevent damaging the casing or components.

The weight of every single device is given in this manual.

### 5.3 INSPECTION UPON RECEPTION

When you receive the device please check all its parts, in order to make sure that it has not been damaged during transport.

Any damage must be reported to the carrier, by filling in the relevant section on the delivery note and specifying the type of damage.



Any type of complaint must be sent in writing within eight days from receiving the goods.

### 5.4 STORAGE

In the event of extended storage keep the devices away from dust and sources of vibration and heat.



The Manufacturer disclaims any liability for damage due to incorrect unloading failure to protect the device from the elements.

### 5.5 HANDLING DEVICE IN OPERATING CONDITIONS

J-Master<sup>10</sup> device is easy movable in various environments (see Chapter 4 "Technical Data").

## 6 - INSTALLATION AND COMMISSIONING



**ATTENTION!** Before carrying out any operation on the devices read **ALL** the instructions in this manual carefully.

Definitions:		
<p><b>USER:</b> Person, organisation or company who or which has purchased or rented the device and is going to use it for the intended purposes.</p>	<p><b>USER/OPERATOR:</b> Individual who has been authorised by the user to operate the device.</p>	<p><b>QUALIFIED STAFF:</b> Individuals who have completed a specific course and are therefore able to recognise the hazards arising from the use of this device and are able to prevent them.</p>

### 6.1 SAFETY STANDARDS



**The Manufacturer disclaims any liability for failure to comply with the safety and prevention standards as described below.**

**The Manufacturer also disclaims any liability for damage caused by improper use of sanitisers and/or alterations carried out without prior authorisation.**

- The device must be installed in strict accordance with the instructions contained in this manual.
- Wear suitable accident prevention clothing when installing the device, such as: goggles, gloves, etc. as instructed in standard 686/89/EEC and subsequent amendments.
- While performing installation, operate in full safety, in a clean environment clear of obstructions.
- Comply with the laws in force in the country in which the device is installed, regarding the use and disposal of the packaging and products used for cleaning and servicing the device; you should also observe the recommendations given by the manufacturer of such products.
- **Before switching the device on check the integrity of the various components and of the electrical mains to which it is connected, making sure that it is fitted with a circuit breaker upstream of the power line as shown in this manual.**
- Never insert objects of any kind into the device, as coming into contact with live parts or electrical terminals may cause fires or electric shocks.
- Worn or damaged parts must only be repaired or replaced by qualified staff and by following the instructions given in this manual.
- The spare parts must be approved by the Manufacturer.
- In the event of decommissioning or disposing of the device, follow the anti-pollution regulations set out by the country in which the device is installed.
- In doing puncture in walls be sure of not interfere with electric ropes, plumbing and whatever can be damaged.
- Do not pour water or any kind of liquids on the device.
- Do not connect the device to power lines connected to any other electric utilities or devices.

- **Use the type of power supply shown on the label. If you are not sure about the type of power supply available, ask your local retailer or electricity provider for assistance.**
- Do not touch the inside of the device, unless specified otherwise in the instructions contained in this manual.
- Never force the components when assembling: although it is made with high strength materials, the parts of the device can be damaged if handled incorrectly.
- Do not try to perform maintenance work on the device, except where specified in this manual. Opening or removing the outer casing may expose you to dangerous live parts or may involve other risks. All maintenance work must be carried out by authorised staff, except where specified in this manual.
- Unplug the device from the mains and contact qualified staff for assistance in one of the following cases:
  - The device has come into contact with water or liquids of any kind.
  - The device has been exposed to the elements.
  - A malfunction persists despite all the installation and/or maintenance procedures have been performed properly.



**IMPORTANT** The installer and the user, when using the device, must take into account and solve all the other types of risk associated with the system. For example, risks arising from foreign bodies getting into the device or risks due to dangerous flammable or toxic gases at high temperature.

## 6.2 GETTING STARTED

---



- Check that the various components of the device are fully intact.
- Check that the documentation and any accessories for installation are contained in the package.



- Carry the device in its packaging as close as possible to the installation site.
- Do not rest weights or tools on the device, or place it on an unstable surface.

## 6.3 CHOOSING THE INSTALLATION SITE

---



- Do not put the device in places where there are flammable gases, acidic, aggressive and corrosive substances that can damage the various components beyond repair.
- Provide a minimum clearance, in order to install the device and carry out routine and special maintenance.

## 6.4 INSTALLING THE DEVICE

The **J-Master<sup>10</sup>** device is designed to be installed on the wall in civil (or similar) environments not subject to bad weather or the presence of water. The box is secured with special plugs (see the "attachments" chapter).



The recommended installation height is 1500 mm from the floor; it is recommended to leave at least 200 mm of free space around the device.

The device has 2 accesses for power supply (24Vdc) and for signals (RS485 e RJ45).

The accesses are arranged on the bottom of the box through a 100x60 window and on the lower part of the container through a Ø16 mm hole.



QR code for downloading the user/maintenance manual.

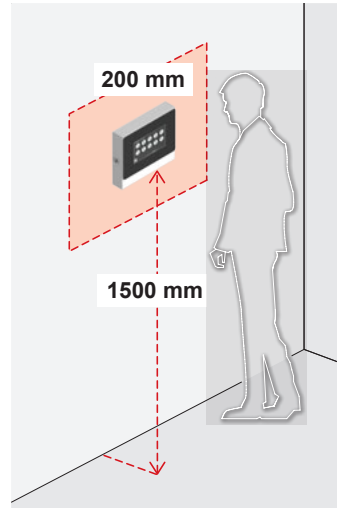

## 6.5 ELECTRICAL CONNECTIONS



**ATTENTION! BEFORE STARTING ANY OPERATION, MAKE SURE THAT THE MAIN POWER SUPPLY IS DISCONNECTED!**

- The electrical connections must be carried out following the instructions provided in this manual.
- **Make sure that voltage and frequency of the electric line correspond to those provided on the name plate.**



**WARNING!** Using power supply that does not meet the requirements requested by the device could resolve in damaging the device or part of it.

- The electrical mains of the **J-Master<sup>10</sup>** device must be used for the device only, there must be no other devices powered by the same power line. Do not use adapters, power strips and/or extension cords.
- Make the connection with cables with a suitable cross-section and in compliance with local standards.
- **The installer must see to it to assemble the device as close to the power disconnecter as possible, according to standards in force and as far as necessary to protect the electrical parts.**

## 6.6 POWER SUPPLY AND CONTROL SIGNALS

The display used for **J-Master<sup>10</sup>** is a 4.3" touch screen device that must be powered (on pins 1-2 of the terminal block) via a specific power supply with an output voltage of 24Vdc and a maximum current of 0.63A (supplied). The power supply must be supplied with a mains voltage of 230Vac 50Hz.



It is recommended to install protection against overload and short circuit upstream of the power supply and in the immediate vicinity, in order to safeguard the system in the event of a fault.

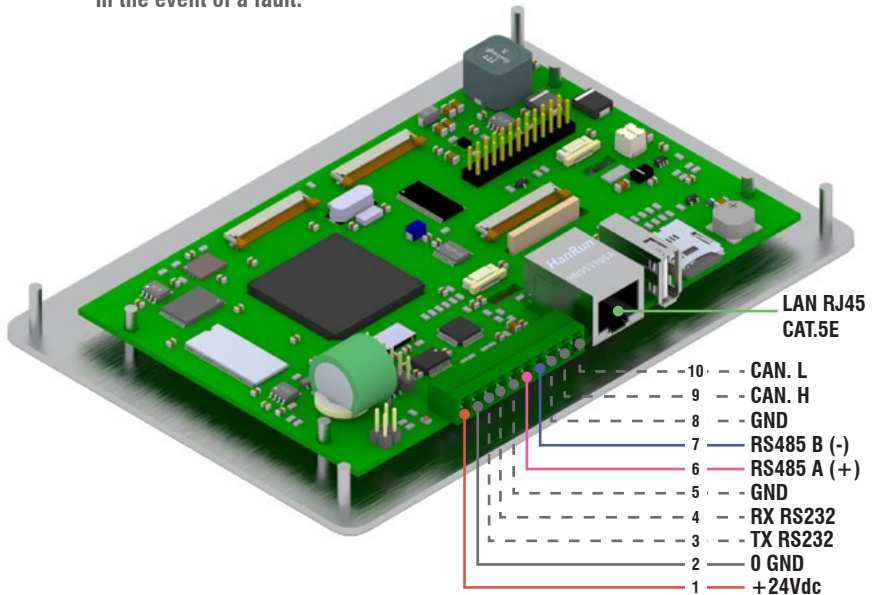

**J-Master<sup>10</sup>** manages 1 to 10 devices equipped with board for remote control (JX11000042). In order to manage the devices, an RS485 serial line with Modbus protocol must be created that will connect the J-Master10 with all the devices present.

The connection must start from the display (Pin 6-7) and make in/out on all devices up to the last one which, unlike the others, will be programmed as a line terminator (it is recommended not to invert the polarities of the serial). The cable to be used must be 2-conductor + earth twisted and shielded (Belden recommended).



Each board must have a unique address that will start from 1 and reach of 10 (example: if there are 4 devices, the addresses will be 1, 2, 3 and 4).

J-Master<sup>10</sup>, in addition to the management adjacent to the device, has the possibility of being displayed and used also in remote mode (only on local network) via a PC and a specific VNC control program.

To use this function, you must connect, via data cable (category 5E or higher), the display to the switch/router of the local network. The RJ45 connection port is located on the back of the display next to the 10-pin green connector for power and signals.

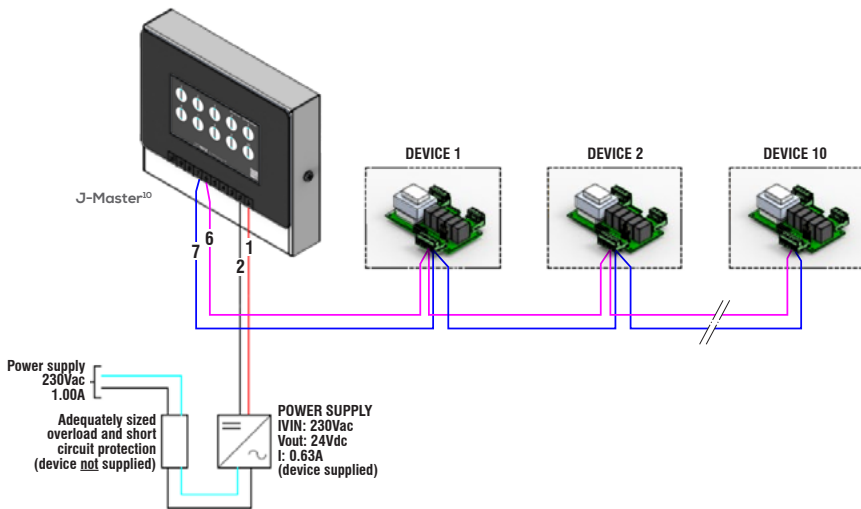

## 7 - User Interface

J-Master<sup>10</sup> allows the user to view the status of connected devices.

The user will be able to:

- View devices;
- View if devices are correctly connected to the Modbus RS485 serial port;
- View whether the device is on or off;
- View any reports (generator maintenance, generator replacement, fault);
- View the percentage of operating hours and the wear status of the generators.



The software allows, as previously indicated, the management of from 1 to 10 devices (see the example screens below).

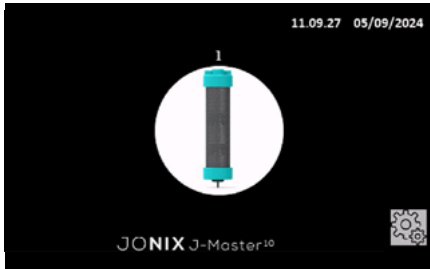

Displaying of the device correctly powered and connected to the RS485 Modbus serial communication in **stand by** will appear as shown in the screenshot on the right:

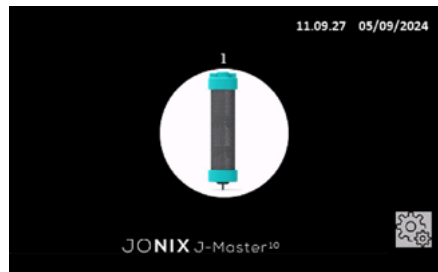

Displaying of the device not correctly connected to the serial line will be as follows:



NOTE: During regular operation there may be times when the devices in the field report "not connected" for a few seconds (maximum 40"). This is due to magnetic interference that "dirty" the control signal.

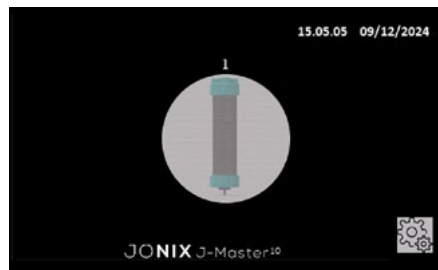

The activated device display will look like the screenshot on the right:



If one or more devices require periodic maintenance (cleaning of the generators) a **Flashing yellow “LED”** message, corresponding to each device, positioned in the top right of the corresponding icon and the central “maintenance required” text will appear.

The maintenance required display will appear as shown on the right:



If one or more devices require generator replacement, a **Steady yellow “LED”** message corresponding to each device, positioned in the top right of the relevant icon and the central “replacement required” text will appear.

The replacement required display will appear as shown in the screen on the right:

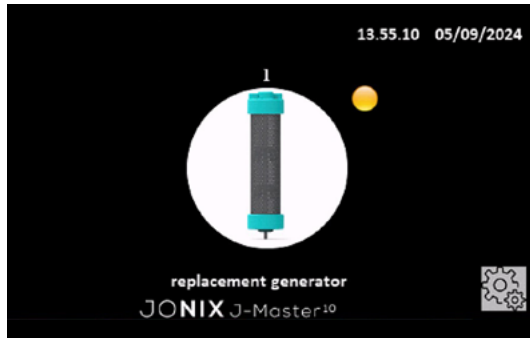

Clicking on each device will access the page dedicated to the specific information of the selected device.

This section will display:

- **the address** of the peripheral device (from 1 to 10);
- the command mode (**Stand Alone**: external contact; **Modbus**: from program to display);
- The **threshold limit** of the operating hours during which the generators are scheduled to be cleaned (Maintenance) and replaced (Replacement);
- the **hours of use** of the generators since the last maintenance or replacement intervention;
- the **percentage of generator wear condition** with respect to the thresholds, in particular:
  - **Replacement**: 0%=new generator, 100%=generator to be replaced.
  - **Maintenance**: 0%= new or just cleaned generator, Maintenance 100%=generator to be cleaned).

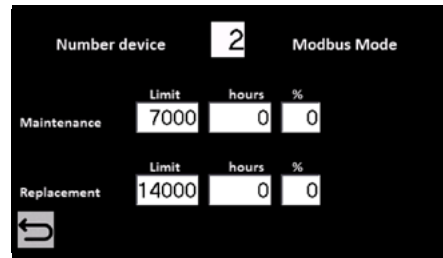
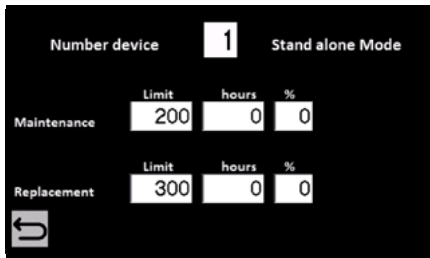

If the display is inactive for more than 3 minutes, the following screen saver will appear:



To return to the device view and to remove the screen saver, simply press in the clock circle.



In the event of an anomaly or when one of the devices requires assistance, two yellow icons with an exclamation mark (!) will appear on the sides of the clock to signal the requirement for intervention of one or more devices.



The display can be connected to a local LAN network. Everything described above can be viewed/executed remotely via a PC connected to the same network. To do this it will be necessary to configure the dedicated remote viewing VNC program.



**In order to perform maintenance on generators or to replace them correctly, always remember to check the instructions in the specific manuals of the devices.**



If the display indicates the need for maintenance or replacement of the generators in the devices, the latter will continue to function even if with a lower level of sanitising efficiency proportionally to their level of dirtiness.

**However, it is advisable to arrange for technicians to intervene for maintenance and/or replacement of the generators no later than 102% of the operating hours of the equipment to avoid the occurrence of electronic problems.**

## 8 - Maintenance Technician Interface

In addition to the user-specific display functions, **J-Master<sup>10</sup>** has a password-protected Maintenance area that is used to program and reset the devices connected to the display.

The maintenance technician will be able to:

- Set the display date and time;
- Set the IP address of the internal local network;
- Change language;
- Schedule time slots for device operation;
- Reset the parameters after performing the intervention requested on the display.

Access in **Maintenance Technician** mode is possible by pressing the grey icon

with gears  located in the bottom right of the main screen:

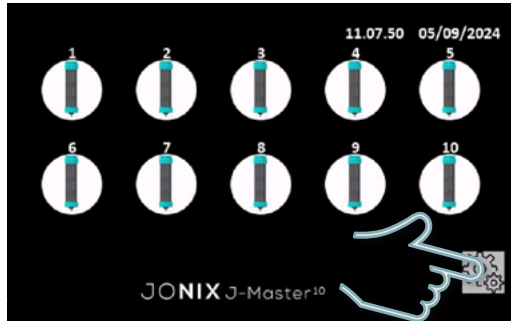

Press this icon to go to the protected area where it will be necessary to enter the password:

 Pressing the white bar above the gears will open a keypad with which to enter the password.

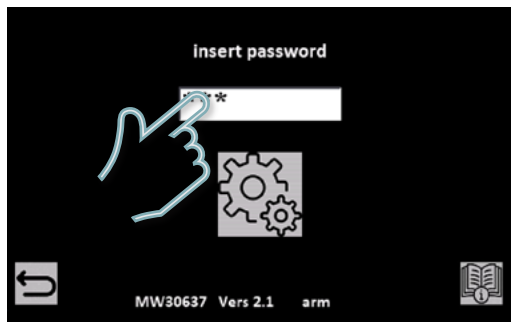

 By pressing the icon on the right  you access the QR code display screen for downloading the user/maintenance manual.

 By default the password is 118 but it can be customised by the installer or by the company Jonix s.p.a.

Press the "Ent" key  to confirm the keypad code.



press the central grey icon with the gears  to access the Maintenance Technician menu.

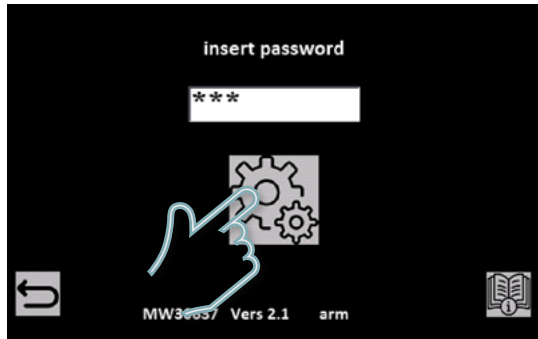

Press the "Clock" key to access the date and time settings:

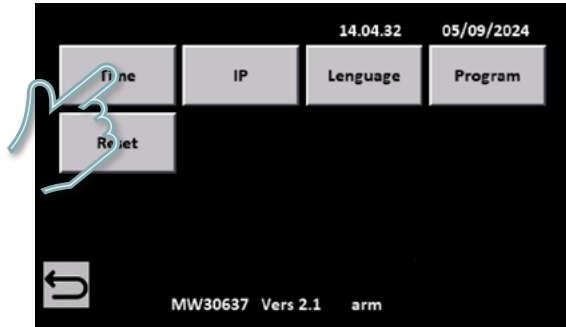



After setting the time and date, to save press the save icon in the bottom left .



 To return to the main menu press the green icon in the bottom right .

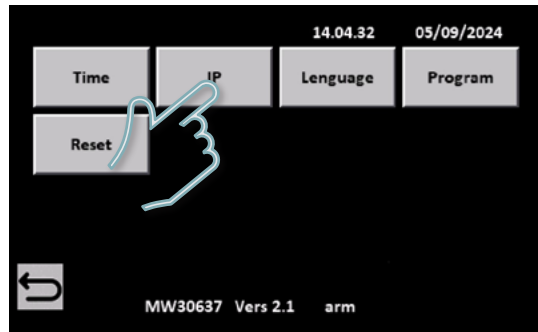

Press the “IP” key to generate the static IP with which to remotely access the display.



Setting the 4 IP address values (by pressing on the white boxes), save press the save icon in the bottom left .

 To return to the main menu press the green icon in the bottom right .

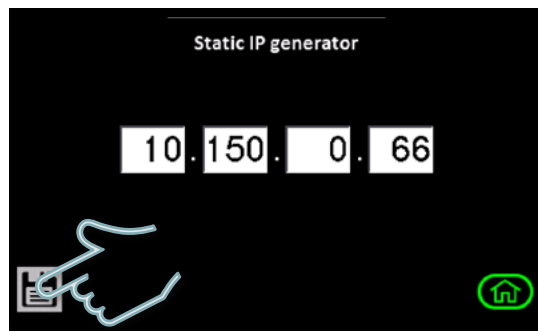

 **Once the IP address is set, reboot the display by unplugging and plugging in again the device, to make the configuration effective.**

By pressing the "**Languages**" key it will be possible to change the language in which the various operations on the display are described.

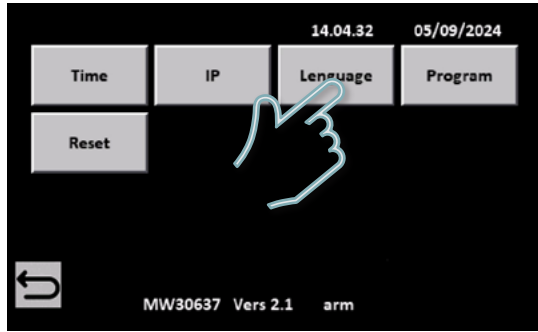

The languages available are Italian, German, French, Spanish and English. To change language simply press on the flag.



To return to the main menu press the green icon in the bottom right .



By pressing the "**Program**" key it will be possible to set the switching on and off of devices controlled in ModBus mode in certain time slots on certain days of the week.

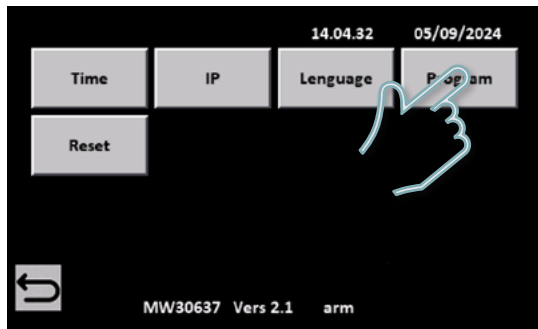

The software can run 10 different and independent programs. Through these programs it is possible to control the various devices individually or combined with certain time slots on certain days. When a day and/or a device is selected the icon changes from red to green with a cross inside to indicate the change of status (in the example screen, device no. 2 will be turned on at 1.25 and turned off at 11.26 every Tuesday of the week).

To activate the program, place the green tick in the top right corner on "Enable" and save everything by pressing the save icon in the bottom left .



To return to the main menu press the green icon in the bottom right .



The icons in grey  represent devices that cannot be controlled/managed because they are not present in the communication network and/or are not activated. In the example, only devices 1 and 2 (enabled) can be controlled, while devices 3 to 10 are not enabled. **Adding devices can only be performed by Jonix spa or by an authorised installer.**



When creating programs, it is advisable not to have the same device with different time slots that overlap. (example: program 1 device 1 active: Monday 8.00am to 3.00pm; program 2 device 1 active: Monday 9.00am to 12.00pm) otherwise, to avoid command conflicts, the program cancels the device power on.

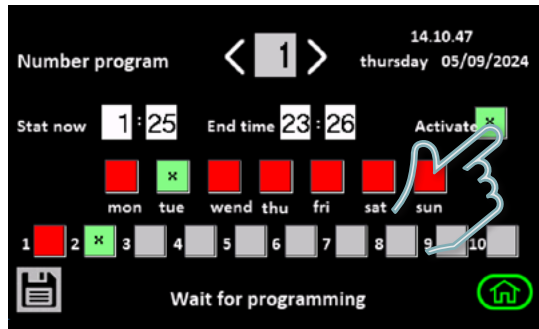

Press the "Reset" key to enter the section dedicated to restoring device parameters. Once the device signals the request for intervention, the maintenance technician must first perform the requested intervention; in the event of:

- **Maintenance:** clean the generators.
- **Replacement:** change the generators.

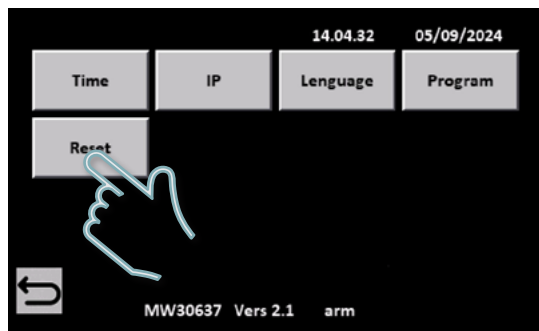

Following the intervention, the parameters will be restored. As can be seen in the screenshots, a red "LED" has been inserted to indicate which parameter to restore.

**Maintenance:**

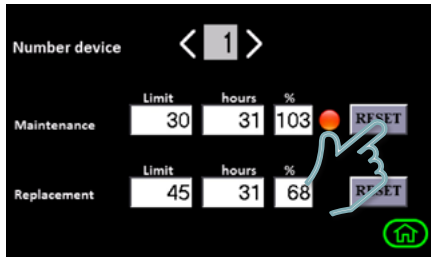

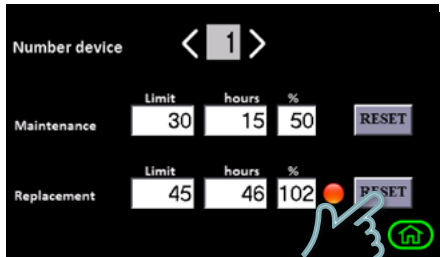

**Replacement:**





 Once the reset is performed, the hour meter will be reset to zero.

In case of **Maintenance Reset**, that is, the intervention concerns cleaning the generators, only the count of hours relating to maintenance is reset.

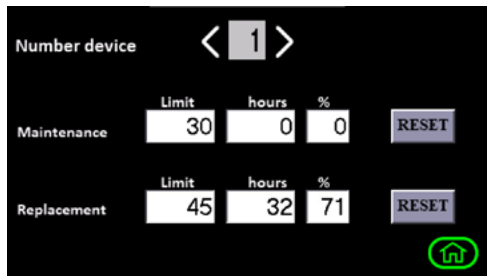
 To return to the main menu press the green icon in the bottom right .



In case of **Replacement Reset**, that is, the generators are replaced, both the hour meters are set to "0" as the equipment is restored to "as new".

 To return to the main menu press the green icon in the bottom right .

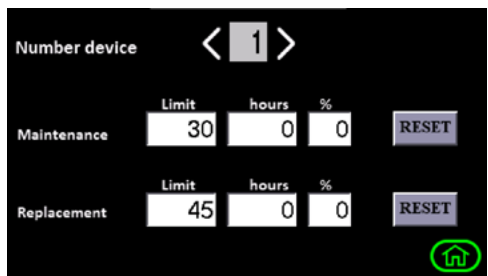

 If for any reason, such as scheduled maintenance on the system or an accidental breakage of the generators, it is possible to reset the hour meters at any time.

 In order to perform maintenance on generators or to replace them correctly, always remember to check the instructions in the specific manuals of the devices.

 Technicians are advised to intervene for maintenance and/or replacement of the generators no later than 102% of generator wear to avoid electronic problems.

## 9 - SuperAdministrator Interface (Only for qualified technicians)

The SuperAdmin section of the **J-Master<sup>10</sup>** software allows the qualified technician to completely program the supervision system.

In addition to User view and Maintenance Technician scheduling, the SuperAdmin can:

- Change and reset the maintenance technician passwords;
- Assign or change device addresses;
- Insert or remove devices that are present in the system;
- Change the maintenance and/or replacement thresholds of the generators;
- Change the control mode of the devices from Stand Alone to Modbus and vice-versa;
- Perform a complete reading of the parameters inside the boards;
- Test mode to check peripheral operation and communication signal quality.

The **SuperAdmin** area is accessed, as for the Maintenance Technician, by pressing the grey icon with the gears  located in the bottom right of the main screen:



Press this icon to go to the protected area where it will be necessary to enter the password:



Pressing the white bar above the gears will open a keypad with which to enter the password ( **1018** ).



Press the "Ent" key  to confirm the keypad code.



press the central grey icon with the gears  to access the SuperAdmin menu.



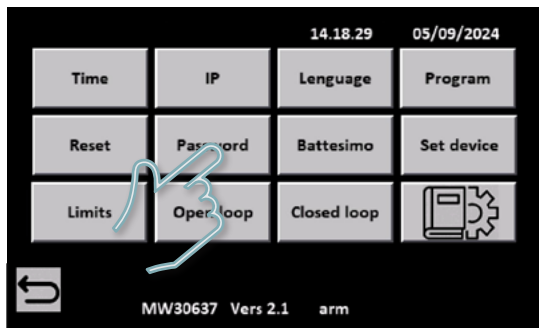

**This menu includes everything described in the Maintenance Technician section** (therefore setting of the Clock, the IP address, the Languages, the Command Program and the Resets); **it also includes additional functions necessary for configuring, verifying and testing the system.**

Press the "Password" key in order to be able to change the Maintenance Technician access code.





The SuperAdmin password is locked and cannot be changed.

To **change the Maintenance Technician password** press on the corresponding bar, indicate the new password via the keypad and confirm via the "Ent" key ; to make the change effective, press the save icon located in the bottom left .

To return to the default settings simply press the red "RESET" key in the top right and always save with the save icon in the bottom left .



To return to the main menu press the green icon in the bottom right .

Press the "Baptism" key to access the section to assign/modify the ID number to a peripheral present in the supervision network.

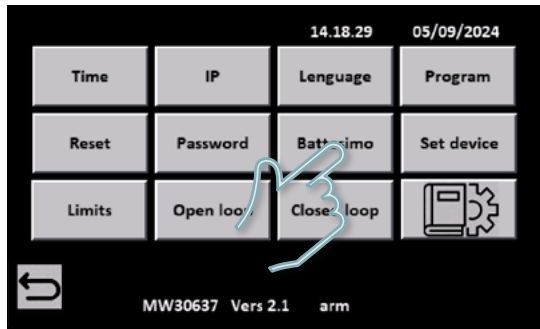

The "Baptism" function has been designed to allow the qualified technician to perform 2 main functions:

- 1) **Create the system with new devices (default address 1) to which to assign IDs from 2 to 10;**
- 2) **Replace damaged or non-functioning equipment, assigning the previously set IDs to them.**

The operation to be performed to modify the identification number of the peripheral device consists, once the system is created and the device is connected, **of indicating the ID currently set in the device** in the top centre icon called "Peripheral number to be changed"; subsequently in the icon in the bottom centre called "New peripheral device number" **select the new ID number to be assigned to the device.**



**Important: J-Master<sup>10</sup> will not recognize the device if the "New device number" is set to a value greater than 10.**

To make the change, press the save icon in the bottom left . As can be seen in the example screenshot, proceeding with saving changes the device address from ID1 to ID2.



To return to the main menu press the green icon in the bottom right .

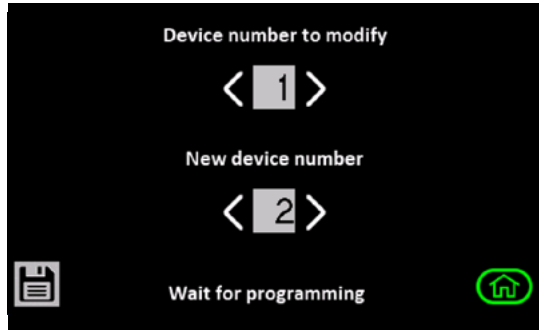

Press the “Set Periph” key to activate/deactivate the peripherals present in the communication/supervision network.

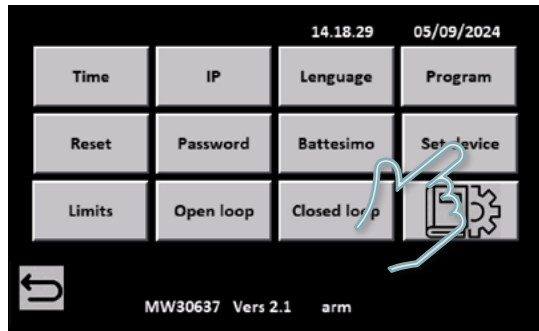

Pressing the “<” “>” arrows, the number increases or decreases, thereby enabling selection of the right quantity of devices connected to the system. By pressing the save icon in the bottom left  the software will search for the number of selected devices and as many icons as the number of requested devices will appear on the display.



The software manages from 1 to 10 devices configured with ID addresses from 1 to 10.





To return to the main menu press the green icon in the bottom right .

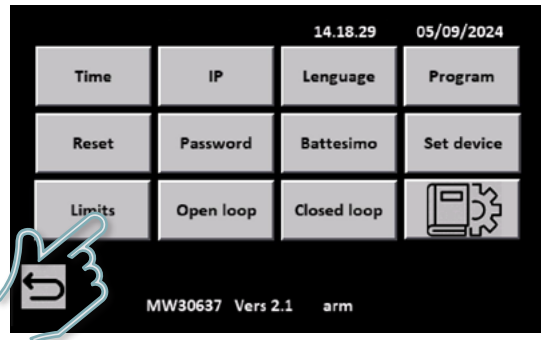

Press the “**Thresholds**” key to set the number of hours to perform maintenance and replacement of the generators. **Any modification of these parameters must be agreed with the technical department of Jonix s.p.a.**



After selecting the device to be modified, press the “READ” key , then set the values and press the corresponding “WRITE” icon .



To return to the main menu press the green icon in the bottom right .

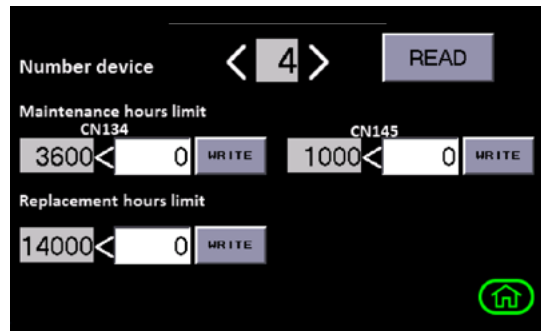

**In the SuperAdmin menu there are the buttons “Open Loop” and “Closed Loop”.** These keys are used by the specialist technician to see all the messages exchanged by **J-Master<sup>10</sup>** with the various electronic device boards and to perform the various tests.

**In order to maximise use of these 2 functions, it is necessary to know the configurable and manageable parameters present in the firmware of the boards (see JX11000042 sensing board Customer Manual-Rev.1 of 25.05.2024) and the communication functions of the Modbus RS485 protocol.**

Press the “Open loop” key to enter the complete query page of the 10 boards, whether or not they are connected to the system:

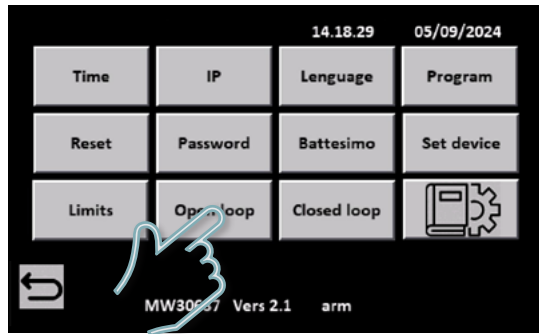

The page consists of 2 screens, which can be consulted with the arrows “<” and “>” in the bottom right, in order to view all the parameters:

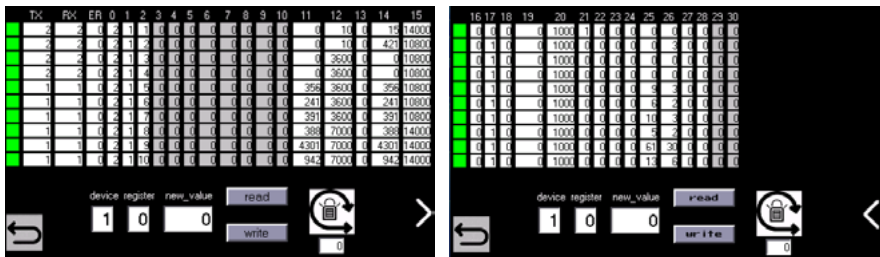



By pressing the “open loop” icon  in the bottom right, the query of all the 10 addresses starts (even if only some are enabled, the program queries them all), and for the devices present, the results of the various parameters are loaded. In addition to checking the parameters, it is also possible to see the data transmission and receipt packets between the display and each board; any communication errors will also be highlighted.

With the “read” key  it is possible to read a single parameter of the specific device while with the “write” key  it is possible to modify a single parameter of the single device.

With these pages it is possible to check and change all the settings of the device management boards (e.g. to change the command from stand-alone to modbus and vice-versa). However, **as any parameter can be modified, incorrectly entering values could block the board or make it illegible**, therefore, before making any changes, always check the manual of the JX11000042 electronic board.

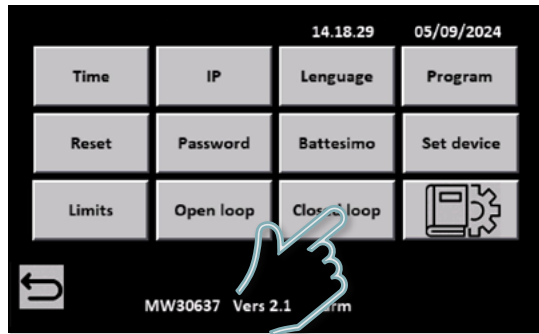
By pressing the “Closed loop” key, it is possible to perform a functional test of the devices present.





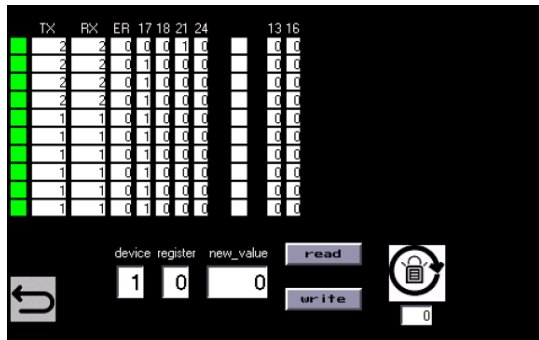

Pressing the key in the bottom right of the “closed loop” test  a function starts which continuously interrogates all the devices alternately, allowing the technician to verify the various messages sent and the modified parameters (only for devices controlled in modbus).

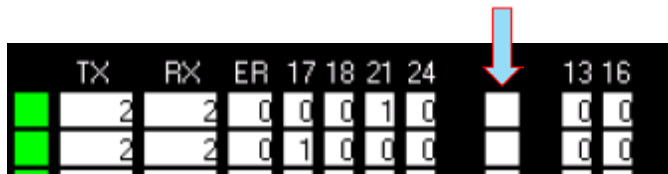

By selecting/deselecting the square in the central column corresponding to the device address, the ionisation will be turned on/off, thus performing a manual operation test.



In the various parameters indicated on the display page it is possible to check the commands sent and any problems relating to the device activation command only. By pressing the “closed loop” key again  the query function will stop; also exiting the test page by pressing the down left arrow , the command to the various devices will be interrupted and the devices will return to their original condition.

Pressing the  button takes you to the QR code display screen which, when scanned allows you to download the enabled technical manual. Pressing the  button takes you back to the previous screen.

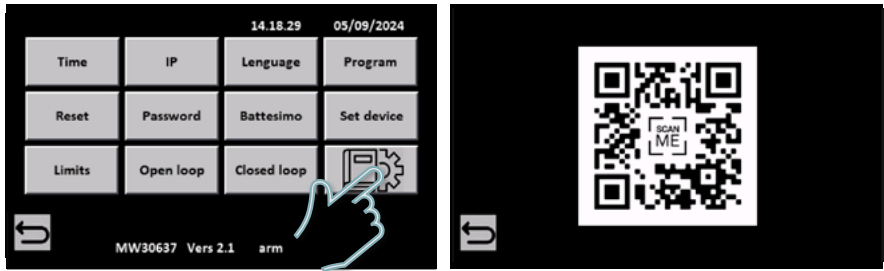

## 10 - MAINTENANCE

J-Master<sup>10</sup> does not require any type of extraordinary maintenance; it is recommended to periodically (at least once every 2 months) clean the surfaces of the container and the display with a damp microfibre cloth.



**Do not use liquid cleaners or sprays, soap or the like.**

## 11 - OPERATIONAL CHECK AND TROUBLESHOOTING

This section summarises the most common problems that may arise when using the unit. Before contacting customer services, carry out the checks listed below.

PROBLEM	POSSIBLE CAUSE	SOLUTION
The display is completely black and does not allow any operations.	The unit is not powered.	Check the presence of mains voltage.
		Make sure the overload and short circuit protection is in the ON position.
		Check the correct functioning of the supplied power supply, via the front LED.
Display devices in gray color display.	No power to field device(s).	Check the presence of mains voltage.
		Check that the plug is connected correctly to the module.
		Check that the protection fuse of the field equipment is intact.
	Missing RS485 serial communication signal.	Check that the signal plug is properly inserted into the connector.
Check the integrity of the signal cables.		
Unable to enter maintenance menu via password.	Password entry error.	Enter the correct password 118.
	Password change by another operator.	Perform password reset (Qualified technician).
Unable to control the device from the display.	Setting device control in "Stand Alone" mode.	Change device command type from "Stand Alone" to Modbus (Qualified technician).
Added new device to system but it is not displayed.	Display not enabled to read added device.	Enable new device with correct address (Technician enabled).
	Device not configured correctly.	Correctly address new device with "Battesimo" function (Qualified technician).



**In the event that you experience a malfunction other than those described above contact qualified staff (retailer, Manufacturer).**

Disconnect the device from the power supply and contact qualified staff for assistance even in the event of one or several of the cases below:

- Water or liquid has been poured onto the device.
- In the event that there is a malfunction despite all the installation procedures have been carried out properly.

## 12 - DISPOSAL

When devices are no longer used they must be disposed of in compliance with the regulations in force in the country of installation. The unit consists of the following materials:

- Stainless steel.
- Galvanized iron.
- Nylon.
- Plastic.
- Paper and Cardboard.
- Wood.



### WASTE ELECTRICAL AND ELECTRONIC EQUIPMENT MANAGEMENT

This product falls within the application scope of the Directive 2012/19/EU concerning the management of waste electrical and electronic equipment (WEEE). Equipment must not be disposed of with household waste as it is made of different materials that can be recycled at special facilities. Please inquire through your municipal authorities as to the location of the eco-friendly waste management sites where waste can be received for disposal and its subsequent recycling as recommended. Furthermore, please note that, when an equivalent appliance is purchased, the seller is expected to collect free of charge the old product to be disposed of. The product is not potentially dangerous for human health and the environment, as it does not contain any harmful substances according to the Directive 2011/65/EU (RoHS), but if disposed of freely in the environment, it might adversely affect the ecosystem.

Read the instructions carefully before using the equipment for the first time. It is strongly recommended not to use the product for any purpose other than that for which it was designed, to prevent the risk electric shock if the product is used incorrectly.

## ATTACHMENTS

### OVERALL DIMENSIONS J-Master<sup>10</sup>

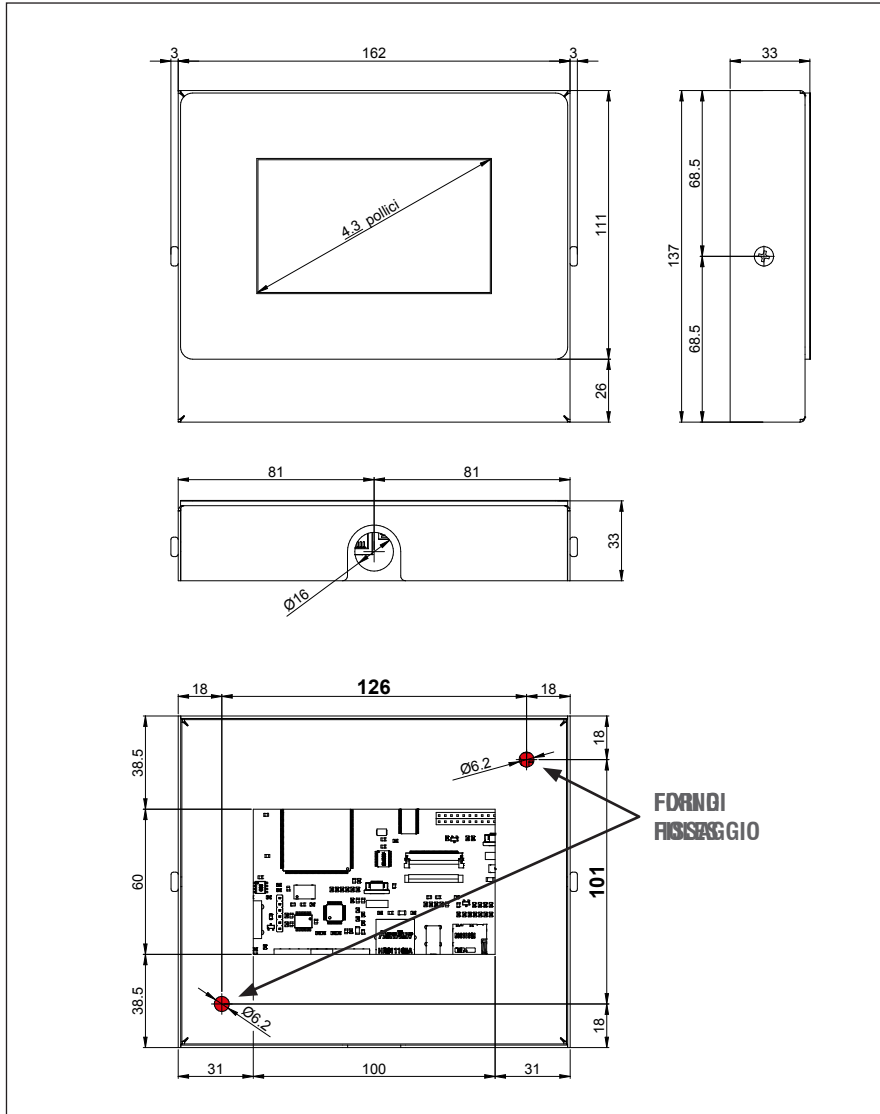







jonixair.com

**JONIX** Spa  
Benefit Corporation

info@jonixair.com  
Certified mail: jonixsr1@legalmail.it



**Registered Office:**  
Viale Spagna 31/33  
35020 Tribano (PD) - Italy  
Ph. +39 049 9588511  
Fax +39 049 9588522

**Operational Headquarters:**  
Via dell'Artigianato, 1  
35020 San Pietro Viminario  
(PD) - Italy  
Ph. +39 0429 760311

**Research and Development  
Headquarters:**  
Via Tegulaia 10/b  
56121 Pisa - Italy  
Ph. +39 050 985165